



Department of  
**Finance and  
Personnel**  
[www.dfpni.gov.uk](http://www.dfpni.gov.uk)

# **Building Regulations (Northern Ireland) 2011**

## **Proposed Guidance Edition**

**of**

## **Technical Booklet H**

## **Stairs, ramps, guarding and protection from impact**

## **Draft for Consultation**

**June 2011**

Technical Booklet H

Draft for Consultation

Inside page to front cover

# Contents

	page
<b>Introduction</b>	<b>0</b>
The Technical Booklets	0
Materials and Workmanship	0
Interaction with other legislation	0
<b>Part H Regulations</b>	<b>0</b>
<b>Guidance - Performance and introduction to provisions</b>	<b>0</b>
<b>Section 1      General</b>	<b>00</b>
Definitions	00
<b>Section 2      Means of approach to a building</b>	<b>00</b>
<b>Ramps and complementary steps on an access route to a building other than a dwelling</b>	<b>00</b>
<b>Ramps and complementary steps on an access route to a dwelling</b>	<b>00</b>
<b>Section 3      Stairs and Ladders</b>	<b>00</b>
Common provisions for all stairs	00
Additional provisions for private stairs and common stairs in blocks of dwellings	00
Additional provisions for stairs in buildings other than dwellings	00
Spiral or helical stairs in a dwelling	00
Stairs and fixed ladders providing access for maintenance	00
<b>Section 4      Ramps</b>	<b>00</b>
Ramps in dwellings	00
Ramps within common areas of a block of dwellings	00
Ramps in buildings other than dwellings	00
<b>Section 5      Guarding</b>	<b>00</b>
General	00

---

Guarding of spiral or helical stairs in a dwelling	00	
Stair or fixed ladder	00	
Vehicle barriers	00	
<b>Section 6</b>	<b>Vehicle loading bays</b>	<b>00</b>
General		00
<b>Section 7</b>	<b>Protection against impact from and trapping by doors</b>	<b>00</b>
General		00
<b>Section 8</b>	<b>Protection from collision with open windows, skylights or ventilators</b>	<b>00</b>
General provisions		00
<b>Appendix A</b>	<b>Domestic roofspaces and roofspace conversions</b>	<b>00</b>
<b>Appendix B</b>	<b>Publications referred to</b>	<b>00</b>

# Introduction

## Technical Booklets

### Purpose of Technical Booklets

This Technical Booklet is one of a series that has been prepared by the Department of Finance and Personnel (the Department) for the purpose of providing practical guidance with respect to the technical requirements of the Building Regulations (Northern Ireland) 2011 (the Building Regulations).

Technical Booklets give practical guidance for most of the more common building situations. If this guidance is followed there will be a presumption of compliance with the requirements of the Building Regulations covered by the guidance. For example, if one particular case is unusual in some way, then 'normal' guidance may not be applicable. It is also important to note that there may be alternative ways of achieving compliance with the relevant requirements. There is therefore no obligation to follow the methods or comply with the standards set out in a Technical Booklet if you prefer to meet the requirements in some other way.

## This Technical Booklet

### Requirements

The guidance contained in this Technical Booklet relates only to the requirements of regulations H3, H4, H5, H6 and H7. Regulation H2 is a prescriptive regulation which does not require guidance to aid compliance. The work will also have to comply with all other requirements of the relevant Building Regulations.

### Diagrams

The diagrams in this Technical Booklet supplement the text. They do not show all the details of construction and are not intended to illustrate compliance with any other requirement of the Building Regulations. They are not necessarily to scale and should not be used as working details.

### British Standards and European Technical Specifications

The Building Regulations are made for the following specific purposes: securing the health, safety, welfare and convenience of people; furthering the conservation of fuel and power; furthering the protection and enhancement of the environment; and promoting sustainable development. Standards and technical approvals are relevant guidance to the extent that they relate to these purposes. However, they may also address other aspects of performance such as serviceability, or aspects which although they relate to health and safety are not covered by the Building Regulations.

In this introduction and throughout this Technical Booklet any reference to a British Standard shall be construed as a reference to –

- (a) a British Standard or British Standard Code of Practice;
- (b) a harmonised standard or other relevant standard of a national standards body of any Member State of the European Economic Area;
- (c) an international standard recognised for use in any Member State of the European Economic Area;
- (d) any appropriate, traditional procedure of manufacture of a Member State of the European Economic Area which has a technical description sufficiently detailed to permit an assessment of the goods or materials for the use specified; or
- (e) a European Technical Approval issued in accordance with the Construction Products Directive,

provided that the proposed standard, code of practice, specification, technical description or European Technical Approval provides, in use, equivalent levels of safety, suitability and fitness for purpose as that provided by the British Standard.

The Department intends from time to time to review the guidance in its Technical Booklets to reflect emerging European harmonised standards. Where a national standard is to be replaced by a European harmonised standard, there will be a co-existence period during which either standard may be referred to. At the end of the co-existence period the national standard will be withdrawn.

### **Products conforming with a European Council Directive**

Any product designed and manufactured to comply with the requirements of a European Council Directive does not have to comply with any other standard or part of a standard, whether British, international or other, which relates to the same characteristic or specific purpose as the EC Directive.

### **CE marked construction products**

Any construction product (within the meaning of the Construction Products Directive) which bears a CE marking shall be treated as if it satisfied the requirements of any appropriate British Standard, British Standard Code of Practice or British Board of Agrément Certificate relating to such a product, where the CE marking relates to the same characteristic or specific purpose as the Standard, Code of Practice or Certificate.

(It is the intention of the Department to review this Introduction to recognise the implementation of new arrangements regarding construction products and CE marking under Regulation (EU) No 305/2011 which will come fully into effect on 1 July 2013.)

### **Named standards**

Where this Technical Booklet makes reference to a named standard, the relevant version of the standard is the one listed in Appendix A. However, if this version has been replaced or updated by the issuing standards body, the new version may be used as a source of guidance provided that it continues to address the relevant requirements of the Building Regulations.

### **Materials and workmanship**

Any work to which a requirement of the Building Regulations applies must, in accordance with Part B of the Building Regulations, be carried out with suitable materials and in a workmanlike manner. You will find guidance in relation to this in Technical Booklet B (Materials and workmanship).

## **Interaction with other legislation**

### **The Workplace (Health, Safety and Welfare) Regulations (Northern Ireland) 1993**

The Workplace (Health, Safety and Welfare) Regulations (Northern Ireland) 1993 SR 1993 No.37 (Workplace Regulations) contain some requirements which affect building design. The main requirements are now covered by the Building Regulations, but for further information see – The Workplace Regulations and the Workplace Health, Safety and Welfare Approved Code of Practice and Guidance (ISBN 0-33711222-3) published by TSO.

The Workplace Regulations apply to the common parts of flats and similar buildings if people such as cleaners, wardens and caretakers are employed to work in these common parts. Where the requirements of the Building Regulations that are covered by this Part do not apply to dwellings, the provisions may still be required in the situations described above in order to satisfy the Workplace Regulations.

# Part H Regulations

It should be noted that the following regulations are the requirements of Part H of the Building Regulations (Northern Ireland) 2011. All parts of the regulations must be read in conjunction with Part A: Interpretation and general of those regulations.

## PART H

### Stairs, ramps, guarding and protection from impact

#### H1 Application and interpretation

- (1) Subject to paragraphs (2), (3), (4) and (5) this Part shall apply to any building or part of a building and the approach thereto.
- (2) The requirements of regulation H4(1) shall not apply—
  - (a) to the extent that compliance therewith would unreasonably obstruct normal movement to, into, out of or within any building;
  - (b) in relation to the two steps at the bottom of a stair where the landing from which the stair rises does not require guarding in accordance with that paragraph;
  - (c) in relation to a flight within a stair with a total rise of less than 600 mm;
  - (d) in relation to a sunken area less than 600 mm in depth; and
  - (e) in relation to a roof or other place to which access is solely for maintenance purposes provided that either—
    - (i) access is infrequent; or
    - (ii) any fall would be—
      - (A) less than 2000 mm; or
      - (B) to an area which does not present a hazard.
- (3) The requirements of regulation H4(2) shall not apply in relation to a car showroom, a garage within the boundary of a dwelling, or a single storey building comprising two or more garages each of which has an area not exceeding 40 m<sup>2</sup>.
- (4) The requirements of regulation H6 shall not apply to—
  - (a) a dwelling; and
  - (b) a door or gate which is part of a lift.
- (5) Insofar as they relate to a dwelling, the requirements of regulation H7 shall only apply to a window, skylight or ventilator which opens over a public route of travel.
- (6) For the purposes of this Part access to any place is infrequent if it takes place on average on less than one occasion a month during the course of a year.
- (7) In this Part—
 

BALCONY includes a gallery;

BARRIER includes a wall or screen;

FLIGHT means that part of a stair or ladder between landings that has a step or a continuous series of steps;

LADDER means a fixed ladder having a flight with a pitch greater than 55°;

LANDING means a platform situated—

- (a) at the top or bottom of a stair, ladder or ramp; and
- (b) between consecutive flights of stairs;

RAMP means an inclined surface which provides a route of travel; and

STAIR means a flight or flights (other than a ladder) and landings that make it possible to pass on foot to another level or levels.

## **H2 Provision of stairs in dwellings**

Within every dwelling of more than one storey there shall be provided between such storeys access by means of a stair complying with the relevant provisions of this Part.

## **H3 Stairs, ladders, ramps and landings**

A stair, ladder and a ramp and its landings, shall offer reasonable safety to people using them to approach, access, use or exit a building.

## **H4 Guarding**

(1) A stair, ladder, ramp, floor, balcony, landing, platform and any roof or other place to which people normally have access (including access for the purpose of maintenance) and a sunken area next to a building, shall, where it is necessary to protect people when approaching, accessing, using or exiting a building from the risk of falling, be adequately guarded with a barrier which does not present a hazard.

(2) Any part of a building which is a vehicle ramp, floor or roof to which vehicles have access shall, where it is necessary to protect people, be adequately guarded with a barrier which does not present a hazard.

## **H5 Vehicle loading bays**

A vehicle loading bay shall be designed and constructed to minimise the risk of people in it from being struck by a vehicle.

## **H6 Protection against impact from and trapping by doors**

(1) In any building a door or gate which —

- (a) is across a main route of travel; or
- (b) can be pushed open from either side,

shall have a means to ensure that people approaching it have a clear view of the space on the opposite side.

(2) In any building a door or gate which slides or opens upwards shall have a means to prevent it from sliding into or falling on any person.

(3) In any building a powered door or gate shall have a means to prevent it trapping any person and a means to open it in the event of a power failure.

## **H7 Protection from collision with open windows, skylights or ventilators**

Reasonable provision shall be made to minimise the risk of people colliding with an open window, skylight or ventilator when moving in or about a building.

# Guidance - Performance and introduction to provisions

## Stairs, ladders, ramps and their landings

### Performance

- 0.1 It is the Department's view the requirements of regulation H3 will be met when a stair, ladder, ramp and its landings afford reasonable safety to people who use them. As there is a correlation between ease of use and safety, a stair that offers passage without undue effort or exertion further reduces the potential for an incident that may result in injury.

An appropriate level of safety can be achieved by different standards of provision, depending on the circumstances; for example, in a public building the standard of provision may be higher than in a dwelling, to reflect the lesser familiarity and greater number of users.

Where access is required only for the purpose of maintenance, greater care can be expected from those gaining access, and it would be reasonable that less demanding provisions could satisfy the requirement.

### General

Provisions for accessibility to and within a building are given in Part R. Provisions for fire safety are given Part E. A stair or a ramp and its landings provided so that people may move to, out of or within a building must comply with the relevant provisions of Part H.

### Introduction to provisions in part 2A of Section 2

In part 2A of Section 2 the guidance deals specifically with various aspects of the geometry and safety features for ramps and complementary steps on access routes to buildings other than dwellings.

### Introduction to provisions in part 2B of Section 2

In part 2B of Section 2 the guidance deals specifically with various aspects of the geometry and safety features for ramps and complementary steps on access routes to dwellings.

### Introduction to provisions in Sections 3 and 4

- 0.2 The guidance in Section 3 is concerned with various aspects of the geometry and safety of stairs and certain ladders. This includes common provisions for all stairs and additional provisions for —
- (a) private stairs
  - (b) common stairs in blocks of flats; and
  - (c) stairs in buildings other than dwellings.

Provisions are also given for spiral and helical stairs in a dwelling and stairs and ladders used solely for the purpose of providing access for maintenance in buildings other than dwellings.

The guidance in Section 4 deals with various aspects of the geometry and safety features of ramps and their landings.

## Guarding

### Performance

- 0.3 It is the Department's view the requirements of regulation H4 will be met if, in order to reduce the risk to the safety of people in or about buildings —
- (a) pedestrian guarding is provided in buildings which is capable of preventing people from being injured by falling from a height
  - (b) vehicle barriers are provided which are capable of resisting or deflecting the impact of vehicles;

An appropriate level of safety can be achieved by different standards of provision for guarding, depending on the circumstances; for example, in a public building the standard of provision may be higher than in a dwelling, to reflect the lesser familiarity and greater number of users.

Where access is required only for the purpose of maintenance, greater care can be expected from those gaining access, and it would be reasonable that less demanding provisions could satisfy the requirement.

### Introduction to provisions in Section 5

- 0.4 The guidance in Section 5 is concerned with reducing the risk of people falling from a height. This includes provisions for guarding flights, ramps, landings and raised floors. This Section also contains guidance in relation to protecting people whenever vehicles have access to a building.

## Vehicle loading bays

### Performance

- 0.5 It is the Department's view the requirements of regulation H5 will be met if, in order to reduce the risk to the safety of people in or about buildings – loading bays are provided with an adequate number of exits or refuges which enable people to avoid being struck or crushed by vehicles.

### Introduction to provisions in Section 6

- 0.6 The guidance in Section 6 deals specifically with reducing the risk to the safety of people in loading bays. This includes the provision of suitable exits or refuges which enable people to avoid being struck or crushed by vehicles.

## Protection against impact from and trapping by doors

### Performance

- 0.7 It is the Department's view the requirements of regulation H6 will be met if, measures are taken to prevent the opening and closing of doors and gates presenting a safety hazard.

### Introduction to provisions in Section 7

- 0.8 The guidance in Section 7 deals with reducing the risk of people being struck by, or trapped by, doors or gates when they are opening or closing.

## Protection from collision with open windows, skylights or ventilators

### Performance

- 0.9 It is the Department's view the requirements of regulation H7 will be met if windows, skylights or ventilators can be left open without the danger of people colliding with them. This could be achieved by —
- (a) installing windows, skylights or ventilators, so that projecting parts are kept away from people moving in or about a building; or
  - (b) installing features which guide people moving in or about a building away from any open window, skylight or ventilator.

An appropriate level of safety can be achieved by different standards of provision, depending on the circumstances; for example, in a public building the standard of provision may be higher than in a dwelling, to reflect the lesser familiarity and greater number of users.

Where access is required only for the purpose of maintenance, greater care can be expected from those gaining access, and it would be reasonable that less demanding provisions could satisfy the requirement.

### Introduction to provisions in Section 8

- 0.10 The guidance in Section 8 is specifically concerned with reducing the risk of people colliding with open windows, skylights or ventilators.

## Section 1 General

### Definitions

1.1 In this Technical Booklet the following definitions apply –

**Entrance storey** – means the storey which contains the principal entrance for the dwelling;

**Flight** – that part of a stair or ladder between landings that has a step or a continuous series of steps;

**Ladder** – a fixed ladder having a flight with a pitch greater than 55°;

**Landing** – a platform situated –

- (a) at the top or bottom of a stair, ladder or ramp; and
- (b) between consecutive flights of stairs;

**Ramp** – an inclined surface which provides a route of travel; and

**Stair** – a flight or flights (other than a ladder) and landings that make it possible to pass on foot to another level or levels.

**Going** (in relation to a step) – the depth of the tread less any overlap with the next tread (see Diagram 1.1).

**Principal storey** – the storey nearest to the entrance storey which contains a habitable room, or if there are two such storeys equally near, either such storey;

**Private stair** – a stair in or intended to be used by only one dwelling.

**Retail building** – shop, department store, supermarket, public house, restaurant with or without assembly area, cafe, hairdresser, wholesale self-selection trading, public area of a bank, building society, betting shop.

**Rise** (in relation to a step) – the height, including the thickness of the tread (see Diagram 1.1).

**Small room** – any room in a dwelling having a floor area not exceeding 4 m<sup>2</sup>.

**Step** – in a dwelling, does not include any threshold which has a height not exceeding 40 mm in the case of an internal doorway or 75 mm in the case of an external doorway.

**Surface width** – the width of a stair or ramp, measured at the tread of a step or the surface of a ramp, between any enclosing walls, strings, upstands, kerbs or guarding.

**Tapered tread** – a tread which has a greater width at one side than at the other and a going which changes at a constant rate throughout its length.

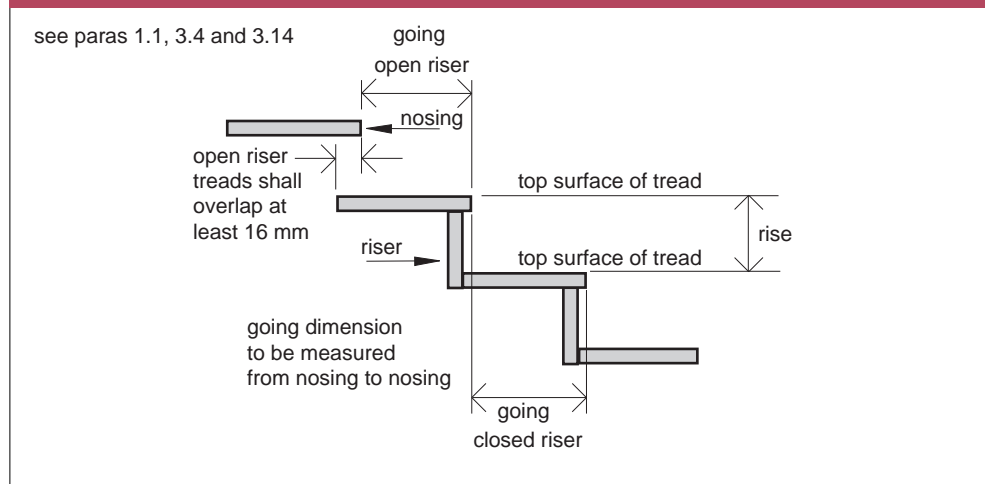
**Diagram 1.1 Measuring rise and going**

### Visual contrast

- 1.2 Visual contrast is the perception of a difference visually between one element of a building and another by reference to their light reflectance values.

Light reflectance value (LRV) is the total quantity of visible light reflected by a surface at all wavelengths and directions when illuminated by a light source.

For people with adequate vision, differences in the nature or the intensity of colour provide adequate visual contrast. Unfortunately, this is not the case for all people who are visually impaired. The main feature of a surface, which appears to be strongly correlated with the ability of visually impaired people to identify differences in colour, is the LRV. Differences in LRV can be used to assess the degree of visual contrast between the surfaces of elements such as handrails, step nosings etc.

The LRV scale runs from 0, which is a perfectly absorbing surface that could be assumed to be totally black, up to 100, which is a perfectly reflective surface that could be considered to be the perfect white. Because of practical influences in any application, black is always greater than 0 and white never equals 100.

A difference in LRV of 30 points or more allows a degree of variability that is required to provide reasonable visual contrast.

## Section 2 Means of approach to a building

- 2.1 Section 2 gives guidance on appropriate levels of safety and convenience for all users where a ramp or a ramp and complimentary steps are to be provided as a means of access to a building.

### **General**

- 2.2 This Section is presented as follows:

Ramps and steps on a means of approach to a building other than a dwelling.

Ramps and steps on a means of approach to a dwelling.

## Ramps and complementary steps on an access route to a building other than a dwelling

### Ramped approach

#### Ramps on access routes

- 2.3 Ramps on access routes should comply with the provisions given in paragraphs 4.14 to 4.25. However, where an external ramp has a crossfall, that crossfall should have a maximum gradient of 1:40.

See Diagram 2.1

### Ramped approach with complementary steps

- 2.4 People with impaired sight risk tripping or losing their balance if there is no warning that there is a change in level. Tripping is most hazardous at the head of a flight of steps when a person is descending. The warning should be placed sufficiently in advance of the hazard to allow time to stop and not be so narrow that it might be missed in a single stride
- 2.5 People who wear callipers or who have stiffness in hip or knee joints are particularly at risk of tripping or catching their feet beneath nosings. People with a weakness on one side or with a sight impairment need the dimensions of the tread to be sufficient for them to be able to place their feet square onto it. If the going is towards the upper end of the dimensional range, the flight may rise to a greater height without the need for an intermediate landing, as the tread is sufficiently deep to allow a person to stand and rest at any point within the flight.

An example of a ramped approach with complementary steps is given in Diagram 2.1

#### Complementary steps

- 2.6 Steps **should** have a uniform –
- (a) rise of not less than 150 mm and not more than 170 mm; and
  - (b) going of not less than 280 mm and not more than 425 mm.

Diagram 2.1 Ramped approach with complementary steps

see paras 2.3 and 2.5

**A length of ramp(s)**

maximum length of ramp - 10 m where the gradient is 1 in 20

**B surface width of ramp(s)**

not less than 1500 mm

**C landing length**

at top and bottom - not less than 1200 mm, between ramps - not less than 1500 mm

**D surface width of steps**

not less than 1200 mm

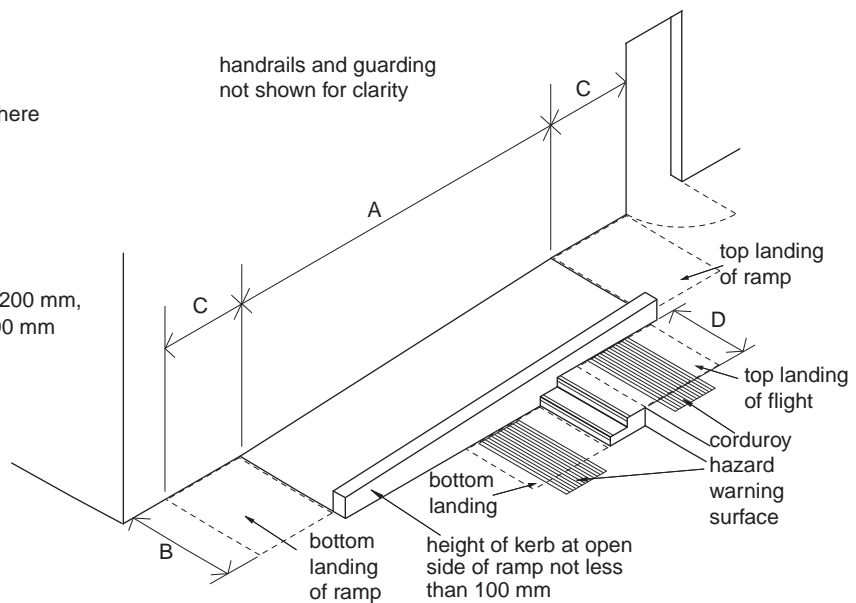

- 2.7** A flight of steps **should** have not less than 2 rises or more than –
- 12 rises where the going of each step is less than 350 mm; or
  - 18 rises where the going of each step is 350 mm or more.
- 2.8** A flight **should** have a surface width of not less than that given in paragraph 3.32.
- 2.9** Steps should also comply with the guidance given in paragraphs 3.33 to 3.36.
- 2.10** To aid people who have a weakness on one side and those with impaired sight, steps **should** have a suitable continuous handrail on each side complying with the provisions of paragraphs 3.38 to 3.43.
- 2.11** To give advance warning of the change in level, a tactile corduroy surface (see Diagram 2.2) **should** be provided on the top and bottom landings of complementary steps. The size of this surface **should** be –
- 800 mm deep when the approach to the steps is head on; or
  - 400 mm deep when the approach to the steps is not head on.
- In either case, the surface **should** extend not less than 400 mm beyond each side of the steps and be located not less than 400 mm from the nearest nosing (see Diagram 2.3).
- 2.12** Where there is access onto any intermediate landing from other than the complementary steps, a tactile corduroy surface 400 mm deep **should** be provided in accordance with Diagram 2.3 (b) or (c).

Diagram 2.2 Corduroy tactile warning surface tiles

see para 2.11

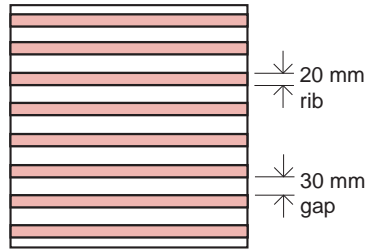

**Tile**

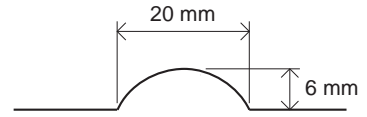

**Rib profile**

**Diagram 2.3 Complementary steps - tactile warnings**

see para 2.11 and 2.12

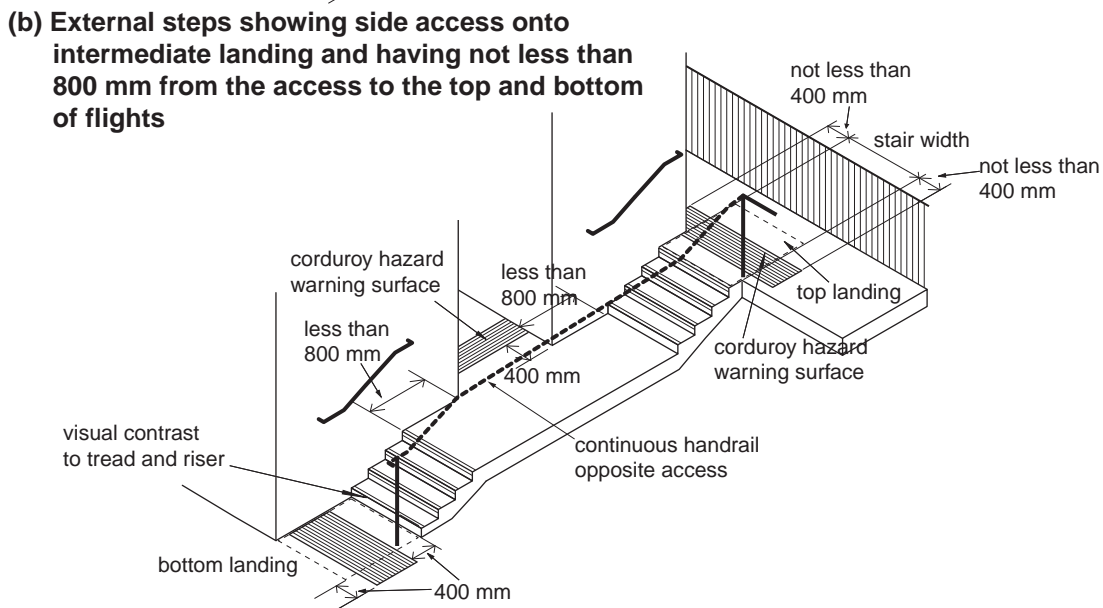
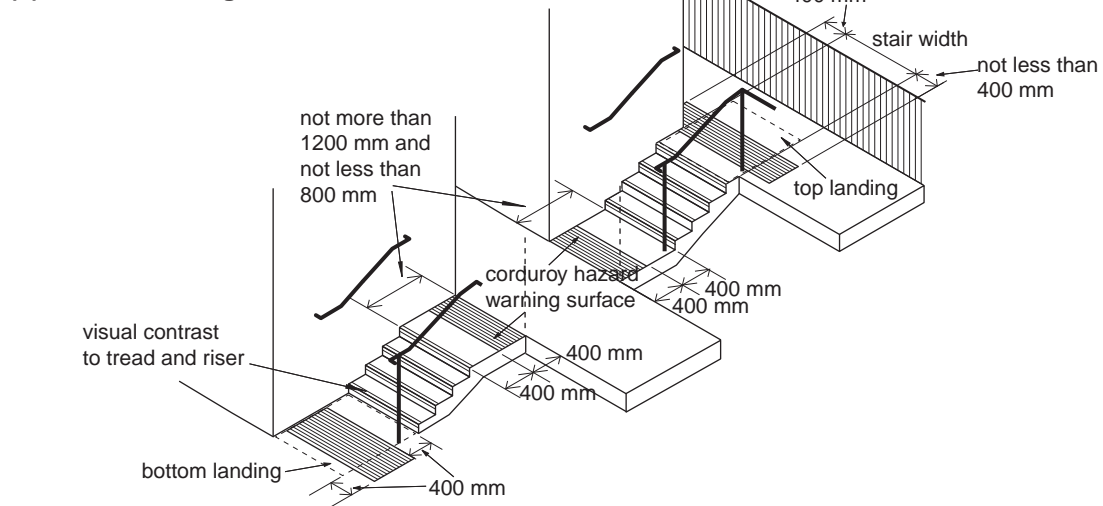
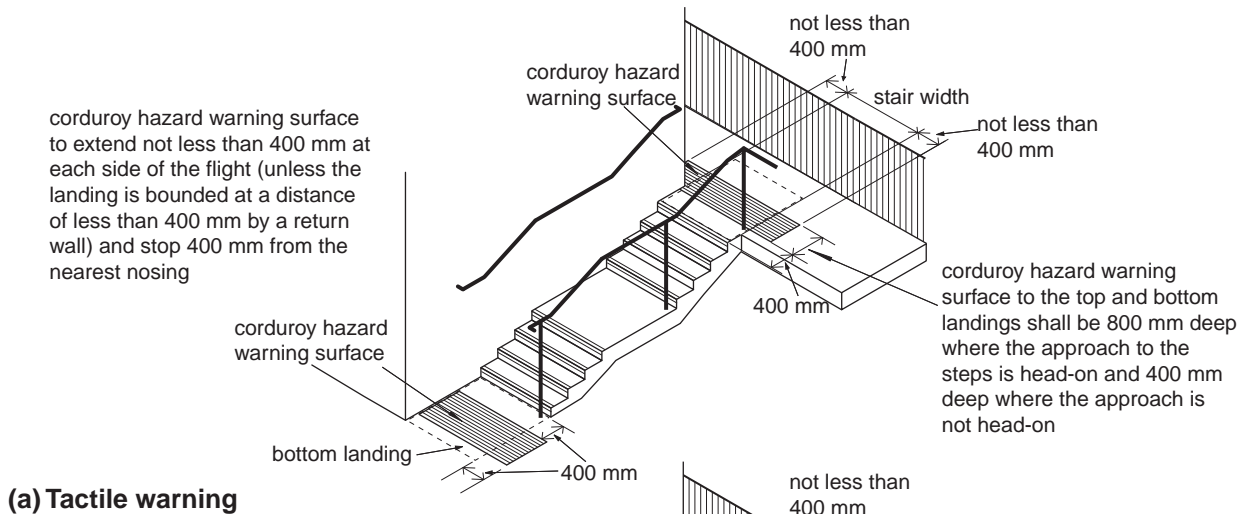

## Ramps and complementary steps on an access route to a dwelling

### Ramped approach

- 2.13 A ramped approach **should** have –
- (a) a surface which is firm and even;
  - (b) an unobstructed width not less than 900 mm;
  - (c) a ramp or ramps not exceeding –
    - (i) 10 m in length where the slope of the ramp does not exceed 1 in 15; or
    - (ii) 5 m in length where the slope of the ramp does not exceed 1 in 12; and
  - (d) landings with an unobstructed length of not less than 1200 mm.

### Stepped approach

- 2.14 A stepped approach **should** have –
- (a) a flight or flights with an unobstructed width of not less than 900 mm;
  - (b) a rise of not more than 1800 mm in each flight of steps;
  - (c) steps with a uniform rise of not less than 75 mm and not more than 150 mm;
  - (d) steps with a uniform going of not less than 280 mm (which in the case of tapered treads shall be measured at a point 270 mm from the narrow end);
  - (e) steps that are not open and have a suitable profile such that the risk of tripping is reduced (see Diagram 2.4);
  - (f) a maximum of 16 steps in a flight;
  - (g) landings with an unobstructed length of not less than 900 mm; and
  - (h) a suitable continuous handrail (see paragraph 2.15) on one side of the flight and at an intermediate landing where the flight comprises three or more steps.
- 2.15 A stepped approach **should** have a suitable handrail which –
- (a) is at a height measured vertically of –
    - (i) 900 mm above the pitch line of a flight of steps; and
    - (ii) 1000 mm above the surface of a landing; and
  - (b) extends not less than 300 mm horizontally beyond the top and bottom nosings of a flight of steps.

### Diagram 2.4 External step profiles

see para 2.14

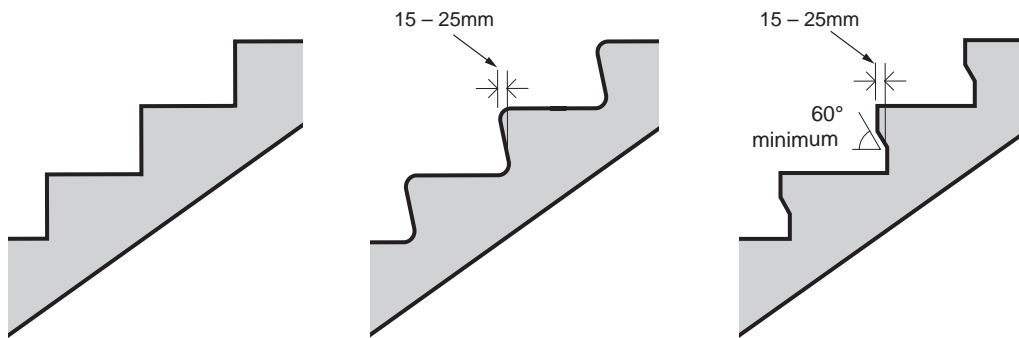

## Section 3 Stairs and ladders

### General

- 3.1 This Section gives guidance on appropriate levels of safety and convenience for all users where a stair is to be provided so that people can move between levels or storeys in a building.

### Common provisions for all stairs

- 3.2 A private stair or a common stair in a block of dwellings, **should** comply with the provisions of paragraphs 3.4 to 3.28.
- 3.3 A stair in a building other than a dwelling or a common stair in a block of dwellings, **should** comply with the provisions of paragraphs 3.4 to 3.11 and 3.29 to 3.42.

### Pitch

- 3.4 The pitch of a flight is controlled by limiting the rise and the going.

Diagram 3.1 shows how to measure the pitch and what is meant by the pitch line. Diagram 1.1 shows how to measure the rise and going (for steps with tapered treads see also paragraph 3.20).

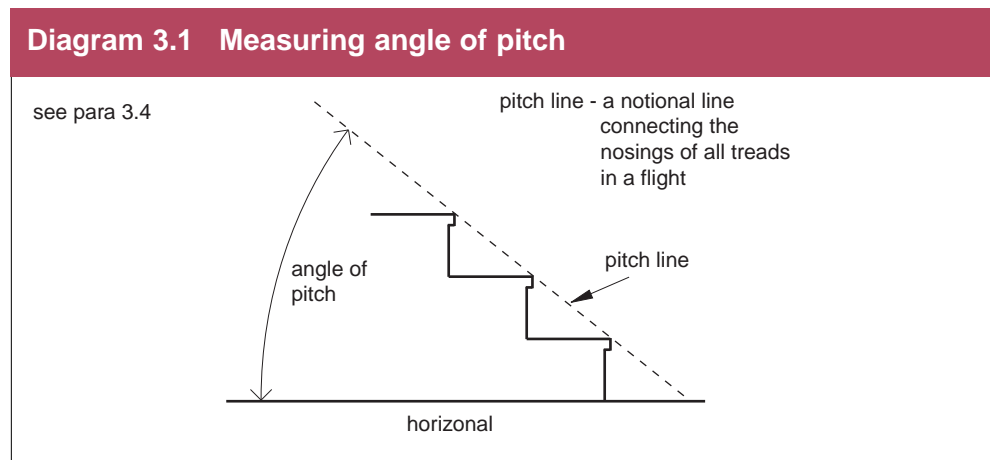

- 3.5 Subject to paragraph 3.12 the relationship between the dimensions of the rise and going is that twice the rise (R) plus the going (G) i.e.  $(2R + G)$  **should** be between 550 mm and 700 mm. The rise and the going are given in Table 3.1.

Table 3.1 Rise and going			
Category	Rise		Going
	minimum (mm)	maximum (mm)	minimum (mm)
1 Private stair	75	220*	220*
2 A common stair in a block of dwellings	75	170	250
3 A stair in any building (other than a private stair or a common stair in a block of dwellings)	150	170	250
Note A stair within more than one category shall be constructed to the more onerous standard * see also paragraph 3.12			

- 3.6 In a flight, the steps **should** all have the same rise and they shall all have the same going.
- 3.7 Where the landing of a stair is formed by the ground and slopes across the width of the flight, then the rise of the step **should** be measured at the mid-point of the width of the flight (see paragraph 3.11).
- 3.8 Steps **should** have level treads which extend for the full width of the flight.

### Headroom

- 3.9 A stair **should** have a clear headroom of not less than 2000 mm over its full length and width.

Headroom is measured vertically from the pitch line of the flight and the level of the landing (see Diagram 3.2(a)).

For roofspace conversions in a dwelling, where it can be demonstrated that there is not enough space to achieve a clear headroom of at least 2000 mm, it would be reasonable for a stair to have headroom as shown in Diagram 3.2(b).

Diagram 3.2 Measuring headroom

see para 3.9

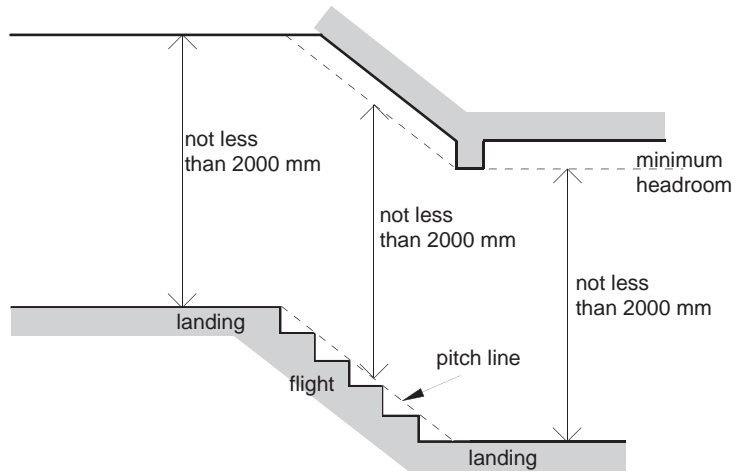

(a) headroom to be achieved under normal circumstances

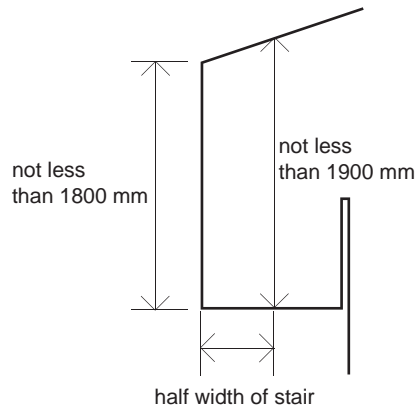

(b) reduced headroom for roofspace conversions

## Change of direction

- 3.10 A stair of more than 36 rises in consecutive flights **should** have at least one change in direction between flights of at least 30° (see Diagram 3.3).

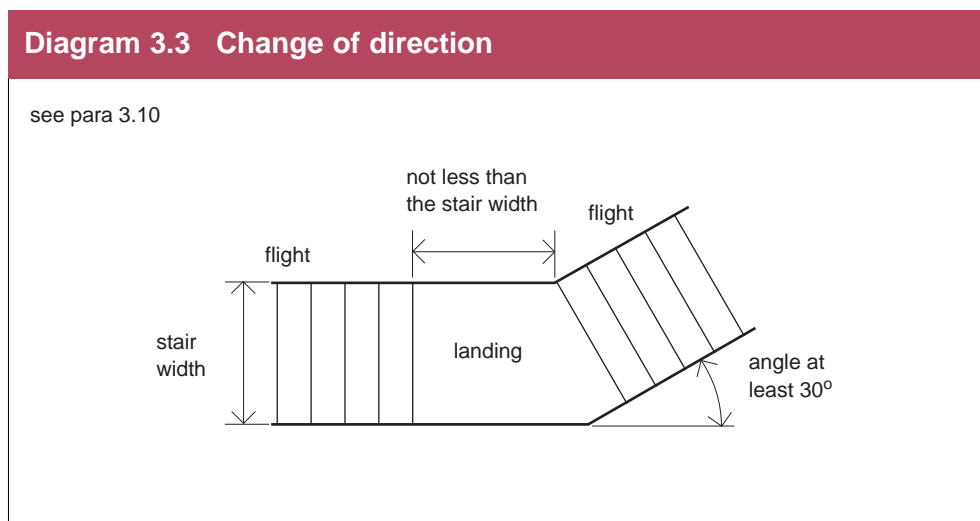

## Landings

- 3.11 Landings **should** be level unless they are formed by the ground at the top or bottom of a flight where they may have a gradient not greater than –
- 1 in 20 in the case of a private stair; or
  - 1 in 60 for all other stairs.

Landings formed by the ground **should** be paved or otherwise made firm.

## Additional provisions for private stairs and common stairs in blocks of dwellings

### Pitch

- 3.12 The pitch of a private stair **should** not exceed 42°, therefore it is not possible to combine a maximum rise with a minimum going.

The rise and the going are given in Table 3.1.

### Width of flights

- 3.13 The minimum unobstructed widths for a flight, in a private stair and a common stair in a block of dwellings, are given in Table 3.2 and **should** be measured in accordance with Diagram 3.4.

**Table 3.2 Widths of flights in a private stair and a common stair in a block of dwellings**

Category	Minimum unobstructed width (mm)
1 Private stair -	
(a) providing access to one room only (not being a kitchen or living room) or to a bathroom and a water closet	600
(b) other than (a) above*	800
2 A common stair in a block of dwellings	1000

**Note**

\* where the private stair -

- (a) is part of the circulation route within the entrance storey; or  
 (b) gives access to the circulation route within the principal storey,  
 the unobstructed width should be not less than 900 mm.

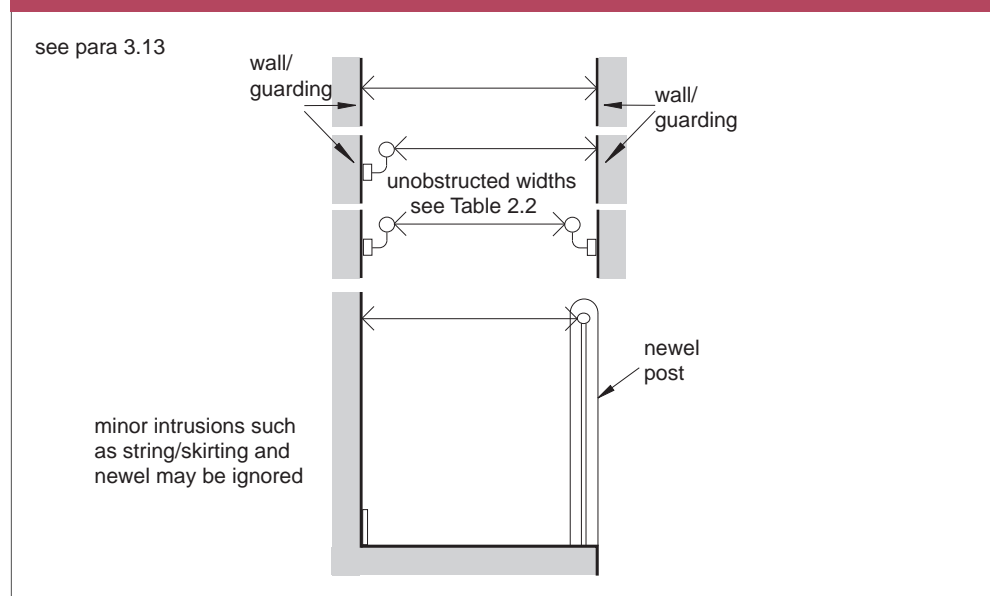
**Diagram 3.4 Measuring the width of a private stair and a common stair in a block of dwellings****Construction of steps**

- 3.14 A private stair may have steps with open rises, but the treads should then overlap each other by at least 16 mm (see Diagram 1.1).

A private stair which has open rises, **should** be constructed so that a 100 mm diameter sphere cannot pass through the open rises.

- 3.15 A common stair in a block of dwellings **should** have steps with rises that are not open, **step nosings which are distinguishable, through permanent contrasting brightness** and have a suitable profile such that the risk of tripping is reduced (see Diagram 3.9 (b)).

- 3.16 The number of rises in a flight **should** be a maximum of 16 and a minimum of 2. However, notwithstanding the provisions of paragraph 3.19, a single step may be provided –
- at the bottom of a stair in a dwelling;
  - at an entrance to a dwelling;
  - between any enclosed porch, outhouse or conservatory and the remainder of a dwelling;
  - where it provides access to a small room; and
  - between a garage and a dwelling.

### Landings

- 3.17 A landing **should** be provided at the top and bottom of every flight.
- The width of a landing **should** be not less than the width of the stair.
- The going of a landing **should** be not less than –
- in a private stair, the width of the flight; and
  - in common stair in a block of dwellings, 1200 mm clear of any door swing onto them**

Part of a floor may be considered as a landing.

- 3.18 **To afford safe passage** a landing **should** be clear of any obstruction. However, in a private stair –
- a door may swing across a landing at the bottom of a flight but only where it will leave a clear space of at least 400 mm across the full width of the flight (see Diagram 3.5); and
  - a door to a cupboard or duct may swing across a landing at –
    - the bottom of a flight; and
    - the top of a flight where it will leave a clear space of 400 mm across the full width of the flight (see Diagram 3.6).

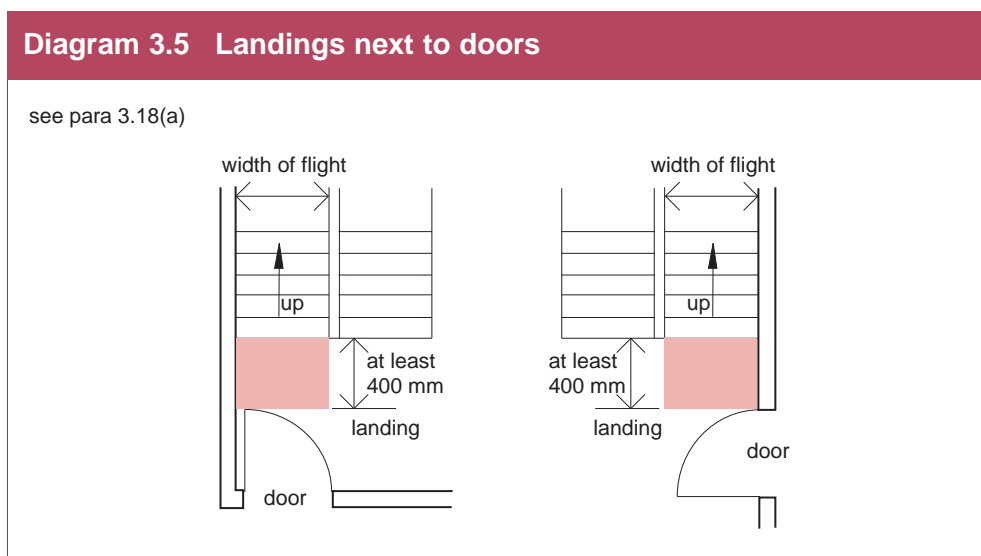
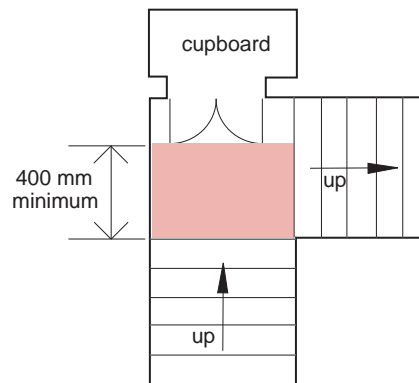

Diagram 3.6 Cupboards onto landings

see para 3.17(b)(ii)



- 3.19 A landing need not be provided between an external flight and a doorway if the rise of the flight is not more than 600 mm and the door slides or opens away from the steps.

Where there is a single step between a garage and a dwelling, a door may open out over the step when the door, in the closed position, has some part of its thickness in line with the riser of the step.

#### Steps with tapered treads

- 3.20 Where steps have tapered treads, the going **should** be measured as follows –
- if the width of the flight is less than 1000 mm, measure in the middle or;
  - if the width of the flight is 1000 mm or more, measure 270 mm from each side.
- (See Diagram 3.7.)
- 3.21 The narrow ends of consecutive treads **should** be on the same side of the stair and have a going of not less than 50 mm (see Diagram 3.7).
- 3.22 The rise and the going measured at the positions, in paragraph 3.20 (a) or (b) whichever is appropriate **should** be within the limits given in paragraphs 3.5 and 3.12 and Table 3.1.
- 3.23 Where a stair consists of straight and tapered treads, the going of the tapered treads **should** be not less than the going of the treads on the straight flight.

Diagram 3.7 Measuring tapered treads

see paras 2.19 and 2.20

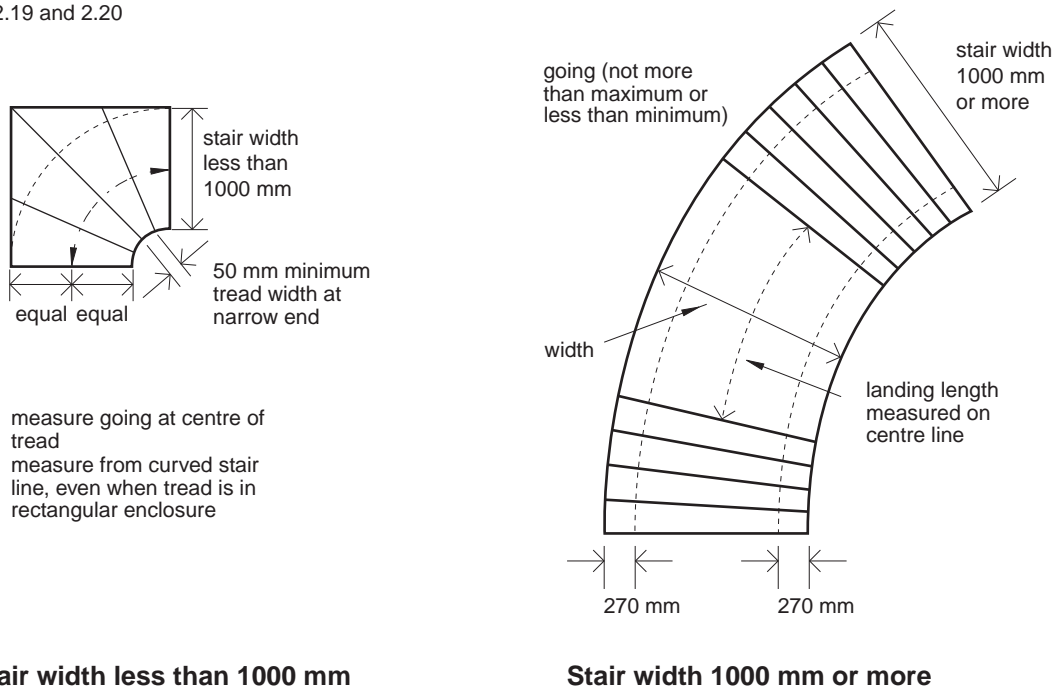

### Handrails

- 3.24 Flights in a private stair with a total rise of more than 600 mm and a common stair in a block of dwellings, **should** have a continuous handrail that gives firm support and a firm grip and be located –
- on at least one side where they are **less than** 1000 mm wide; or
  - on both sides where they are 1000 mm wide **or more**.

Where only one handrail is required on a flight with tapered treads, it **should** be located on the outer side of the flight.

- 3.25 Notwithstanding the provisions of paragraph 3.24, where a private stair -
- is part of the circulation route within the entrance storey of a dwelling; or
  - gives access to the circulation route within the principal storey of a dwelling,

the stair should have a continuous handrail on each side.

- 3.26 Handrails are not required beside the two steps at the bottom of a private stair.
- 3.27 Handrails **should** be at a height measured vertically of between 900 mm and 1000 mm above the pitch line.

Handrails may form the top of guarding.

- 3.28 To give warning of a change in level the handrail to a common stair in a block of dwellings, **should** extend horizontally for a distance of not less than 300 mm, along the top and bottom landings.

## Additional provisions for stairs in buildings other than dwellings

- 3.29 Paragraphs 3.4 to 3.11 and 3.30 to 3.43 apply to a stair which is not a private stair or a common stair in a block of dwellings.

### Pitch

- 3.30 The rise and the going are given in Table 3.1.
- 3.31 There **should** be not less than 2 rises and not more than 12 rises in each flight.

There may be exceptional circumstances where a different rise or greater number of rises in a flight is more appropriate e.g. where there are dimensional constraints imposed by an existing building.

### Width of flights

- 3.32 A flight **should** have a surface width of not less than 1200 mm.

Where a handrail protrudes into the surface width of a flight by more than 100 mm, the surface width **should** be increased accordingly. In any case, the maximum protrusion of a handrail into the surface width of a flight **should** be 110 mm.

A flight of steps which has a surface width wider than 1800 mm, **should** be divided into flights which are not wider than 1800 mm. The minimum surface width of 1200 mm then applies to each flight (see Diagram 3.8).

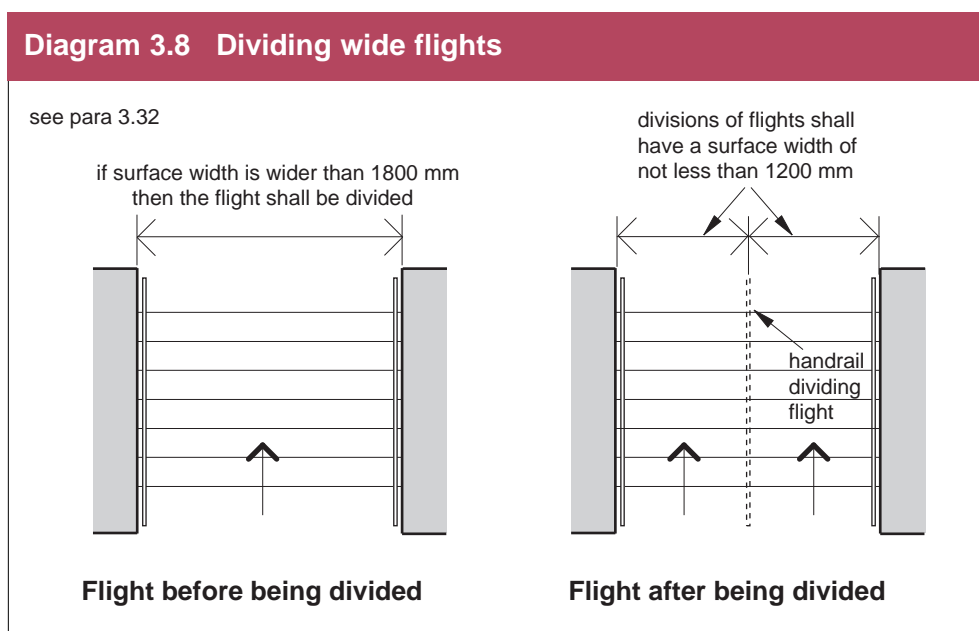

### Construction of steps

- 3.33 For people to appreciate easily where to place their feet, steps **should** have step nosings which are distinguishable through suitable permanent visual contrast. The width of this permanent visual contrast **should** be not less than 50 mm and not more than 60 mm to all treads and risers.
- 3.34 Anything fixed or fitted to a tread or riser **should** not create a trip hazard.

- 3.35 Steps **should** have rises that are not open and have a suitable profile such that the risk of tripping **or people catching their feet beneath the nosing**, is reduced (see Diagram 3.9).

**Diagram 3.9 Details of stairs**

see paras 3.15, 3.34, 3.39 and 3.40

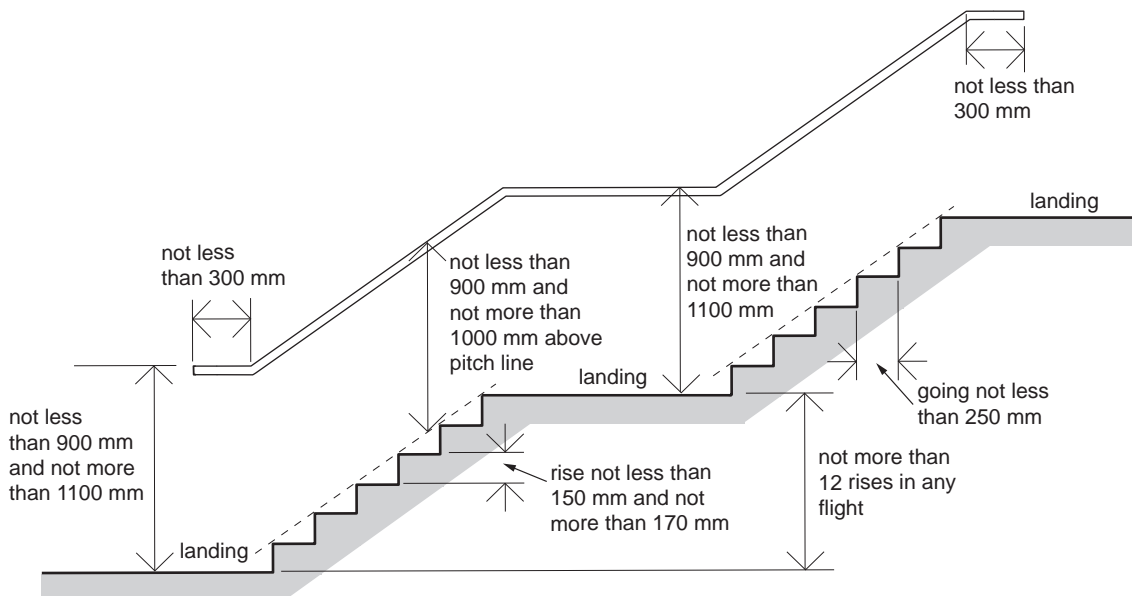

**(a) Stairs and handrails**

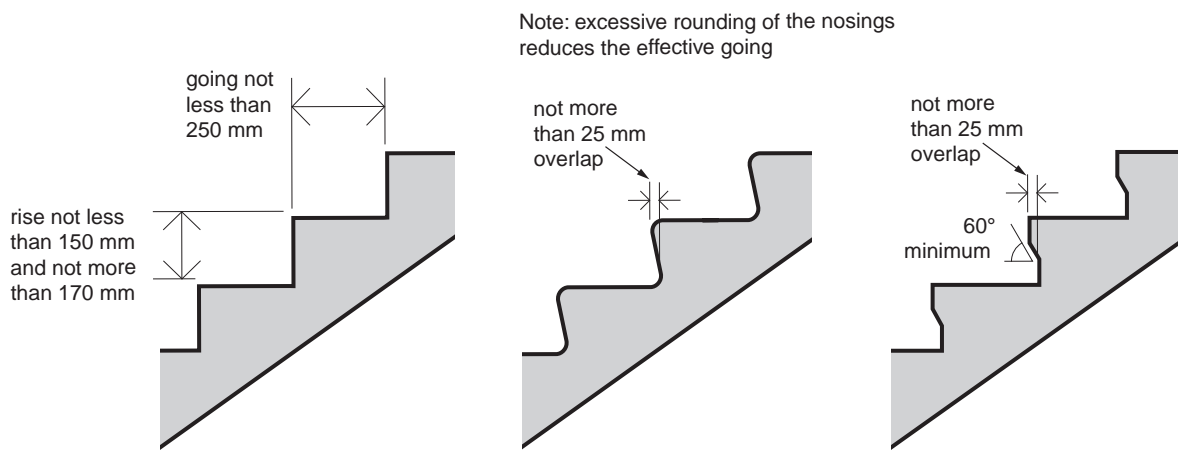

**(b) Examples of suitable step profiles**

**Landings**

- 3.36 A landing **should** be provided at the top and bottom of every flight.
- The width of the landing **should** be not less than the width of the stair.
- To afford safe passage**, the unobstructed length of each landing **should** be not less than 1200 mm clear of any door swing onto it.
- Part of a floor may be considered as a landing.

---

## Handrails

- 3.37** A suitably designed handrail can help prevent people losing their balance when on the stair and can also assist users to ascend by pulling themselves up the stairs.
- 3.38** A stair **should** have a suitable continuous handrail on each side.
- 3.39** A handrail **should** be at a height measured vertically of –
- (a) not less than 900 mm and not more than 1000 mm, above the pitch of a flight; and
  - (b) not less than 900 mm and not more than 1100 mm, above the surface of a landing.

(See Diagram 3.9.)

Where it is decided to provide a second lower handrail, for use by children and people who are short in stature, that handrail should be 600 mm above the pitch of the flight. However, this second lower handrail must not impinge on the protection against falling provided by any necessary guarding.

- 3.40** To give warning of a change in level each end of a handrail **should** extend horizontally for a distance of not less than 300 mm, along the top and bottom landings of a stair, be closed and terminate in a suitable way so that –
- (a) it does not project into a route of travel; and
  - (b) it reduces the risk of clothing being caught.

(See Diagram 3.9.)

- 3.41** Handrails should be rigidly supported in a way that avoids impeding the users grip.

A handrail **should** be –

- (a) not less than 50 mm and not more than 60 mm clear of any adjacent side or enclosing surface wall, or guarding etc.;
- (b) not less than 50 mm clear from the underside of the handrail to any cranked support; and
- (c) not more than 50 mm beyond the outer edge of a flight of steps, to the inner side of the handrail.

(See Diagram 3.10.)

- 3.42** The surface of a handrail **should** be distinguishable through suitable visual contrast from the background against which it is seen.

- 3.43** Handrails should allow users to make a power grip around the whole handrail. A non-circular handrail with a broad horizontal face is as easy to grip as a circular handrail and gives better hand and forearm support.

A handrail **should** have a suitable profile that is gripped easily. Suitable handrail profiles include circular and oval. (see Diagram 3.10).

**Diagram 3.10 Examples of suitable handrails**

see paras 3.41 and 3.43

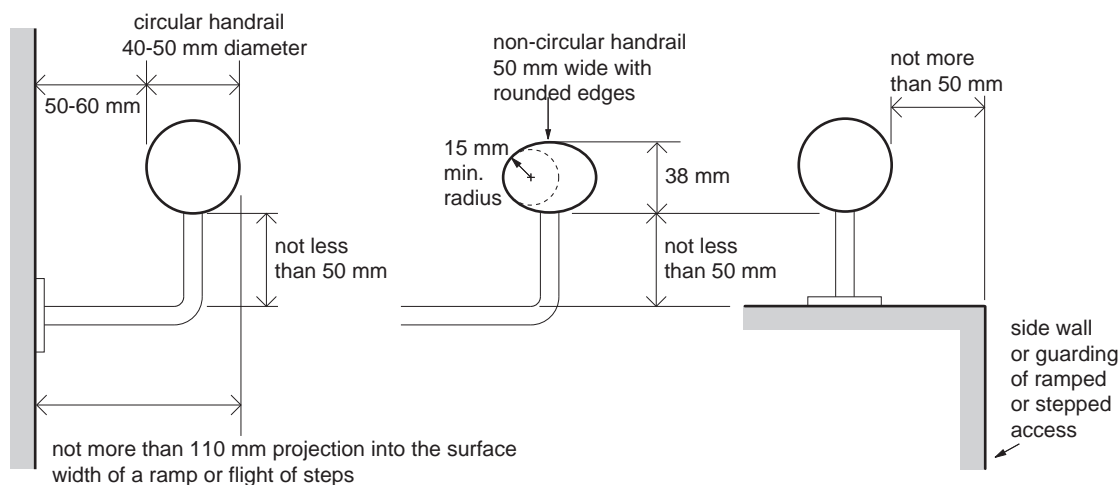

Note: To be suitable for all to use, the profile of a handrail shall incorporate the above features

## Spiral or helical stairs in a dwelling

- 3.44 In a dwelling, a spiral or helical stair should be designed and constructed in accordance with BS 5395-2: Stairs, ladders and walkways. Code of practice for the design of helical and spiral stairs.

## Stairs for limited access in dwellings

- 3.45 When converting the roofspace of a dwelling, space and location are major issues for the stair access. Therefore, due to the constraints of space, it may not always be possible to include a private stair to access a roofspace conversion in a dwelling.

An altering tread stair is designed for use where the maximum space available for a stair is smaller than that required to accommodate a private stair complying with the relevant provisions of this Section.

Before selecting an altering tread stair as a solution to access, all other options must be explored and eliminated as not feasible within the circumstances of the dwelling.

- 3.46 In a dwelling, an alternating tread stair may be used –
- to provide access to a roofspace conversion. Where that conversion contains a habitable room, there should be not more than one habitable room which may include en-suite sanitary accommodation provided it is not the only sanitary accommodation for the dwelling; and
  - where there is insufficient space within the circulation area to accommodate a private stair.

An altering tread stair should –

- (a) contain only straight flights;
- (b) have steps that are uniform with parallel nosings;
- (c) have a going, measured over the widest part of the tread, in accordance with Table 3.1 for a private stair;
- (d) have risers, in accordance with Table 3.1 for a private stair;
- (e) have handrails on both sides;
- (f) have treads that reduce the risk of slipping; and
- (g) where there are open risers, be constructed so that a 100 mm diameter sphere cannot pass through the open risers.

See Diagram 3.11

**Diagram 3.11** Alternating tread stair

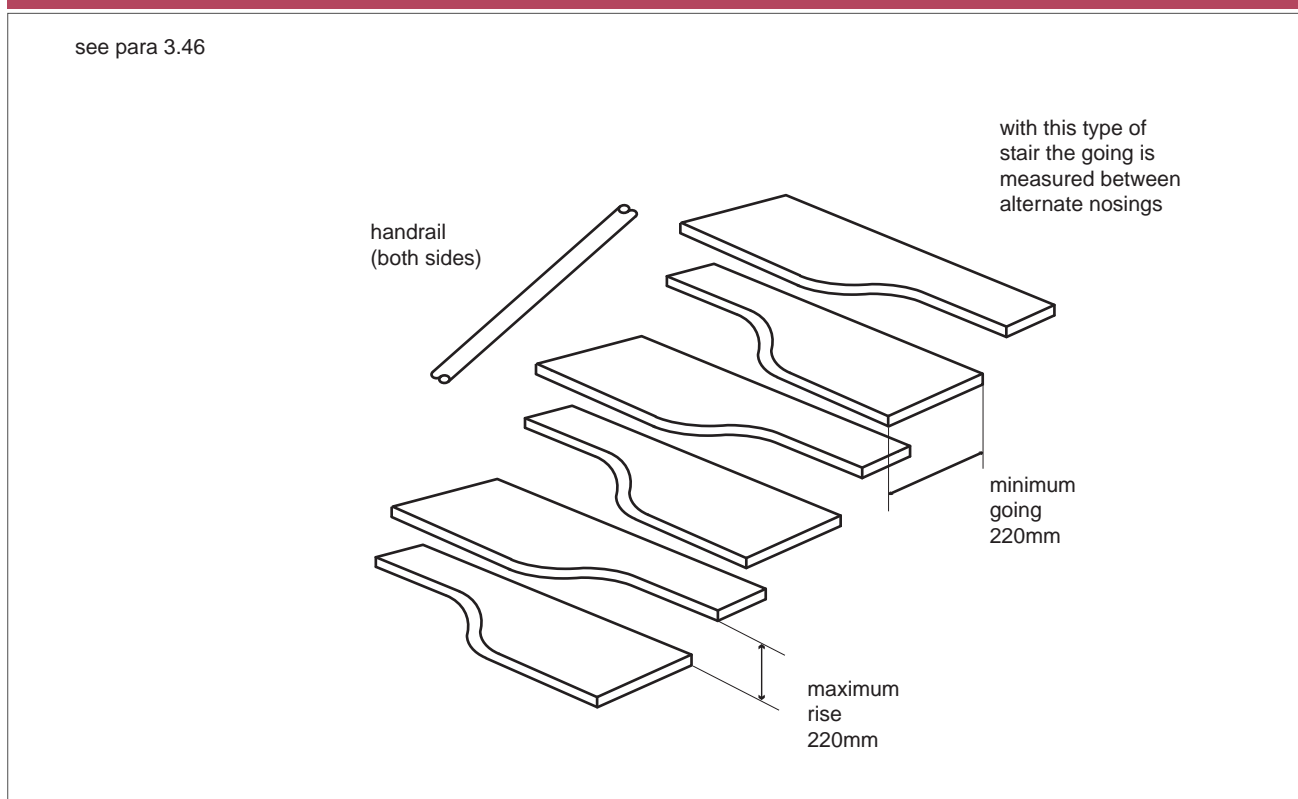

### Stairs and fixed ladders providing access for maintenance

- 3.47 A stair or a fixed ladder in a building other than a dwelling, providing access solely for the purpose of maintenance should be designed and constructed in accordance with either BS 5395-3: Stairs, ladders and walkways. Code of practice for the design of industrial type stairs, permanent ladders or walkways or BS 4211: Specification for permanently fixed ladders

## Section 4 Ramps

### General

- 4.1 This Section gives guidance on appropriate levels of safety and convenience for all users where a ramp is to be provided as a means of circulation within a building

### Dwellings

#### Gradient

- 4.2 A ramp **should** have a gradient not steeper than 1 in 12 and **should** be uniform throughout its length (see Diagram 4.1).

#### Width of ramps

- 4.3 The minimum width for a ramp **should** be the same as that for a flight in a private stair (see paragraph 3.12 and Table 3.2).
- 4.4 The length of a ramp measured on plan, **should** not exceed 10 m (see Diagram 4.1).

#### Landings

- 4.5 Landings **should** be level and be provided at the top and bottom of a ramp (see Diagram 4.1).
- The width and going of a landing **should** be not less than the width of the ramp. Part of a floor may be considered as a landing.
- 4.6 Ramps **should** be clear of obstructions and landings **should** be clear of obstructions other than those described in paragraph 3.18.

#### Headroom

- 4.7 Ramps and associated landings **should** have a clear headroom of not less than 2000 mm over the length and width of the ramp.
- Headroom is measured vertically from the slope of the ramp and the level of the landing.
- (See Diagram 4.1.)

#### Handrails

- 4.8 A ramp or a series of ramps with a total rise of more than 600 mm **should** have a continuous handrail that gives firm support and a firm grip –
- (a) on at least one side where they are 1000 mm wide or less; or
  - (b) on both sides where they are more than 1000 mm wide.

Handrails **should** be at a height measured vertically of between 900 mm and 1000 mm above the surface of the ramp.

Handrails may form the top of guarding.

## Diagram 4.1 Ramp design

see paras 4.2, 4.4, 4.5, 4.7, 4.12 and 4.22

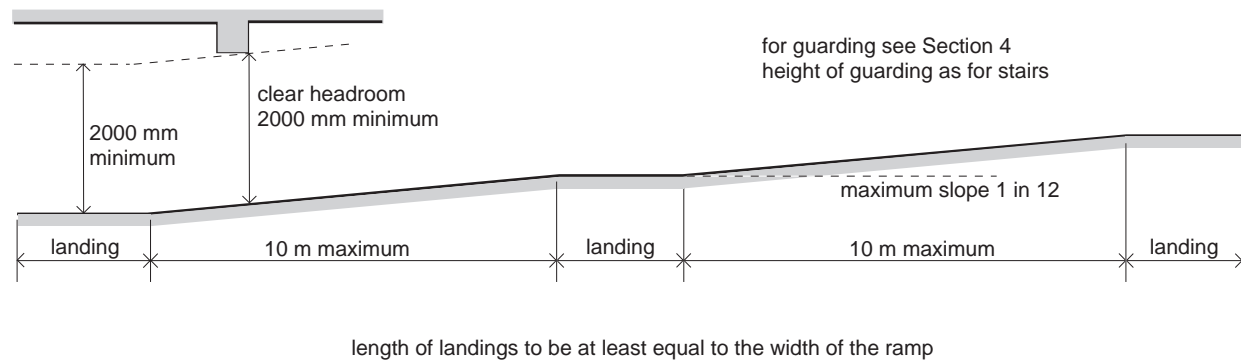

## Common areas of a block of dwellings

### Length and gradient

- 4.9 A ramp **should** be not more than –
- 10 m in length where the gradient of the ramp does not exceed 1 in 15; or
  - 5 m in length where the gradient of the ramp does not exceed 1 in 12.

### Width of ramps

- 4.10 A ramp **should** have a surface width of not less than 1200 mm. Where a handrail is provided, the width at handrail level may be reduced to not less than 1000 mm.

### Landings

- 4.11 Landings **should** be level with an unobstructed length of not less than 1200 mm.

### Headroom

- 4.12 Ramps and associated landings **should** have a clear headroom of not less than 2000 mm over the length and width of the ramp.
- Headroom is measured vertically from the slope of the ramp and the level of the landing (see Diagram 4.1).

### Handrails

- 4.13 A ramp **should** have a suitable continuous handrail on each side if the horizontal length of the ramp is more than 2000 mm.
- Handrails **should** be at a height measured vertically of between 900 mm and 1000 mm above the surface of the ramp, give firm support and allow a firm grip.

## Buildings other than dwellings

- 4.14 Gradients of ramps **should** be as shallow as practicable as steep gradients may not be safe or convenient for all people.

The following provisions apply to a ramp which is not in a dwelling or in a block of dwellings.

### Length and gradient

- 4.15 The maximum length of a ramp is dependent upon its gradient. Table 4.1 gives the maximum length of a ramp for a given gradient.

There may be exceptional circumstances where a different gradient of ramp to that shown in Table 4.1 over a short distance is more appropriate e.g. where there are physical constraints imposed by an existing building.

Gradient of ramp	Maximum length of ramp (m)
1:20	10
1:19	9
1:18	8
1:17	7
1:16	6
1:15	5
1:14	4
1:13	3
1:12	2

### Width of ramps

- 4.16 A ramp or ramps and landings **should** have a surface width of not less than 1500 mm.

Where a handrail protrudes into the surface width of a ramp by more than 100 mm the surface width **should** be increased accordingly. In any case the maximum protrusion of a handrail into the surface width of a ramp **should** be 110 mm.

Where a ramp which has a surface width wider than 1800 mm, **it may** be divided into ramps which are not wider than 1800 mm. The minimum surface width of 1500 mm **will then apply** to each ramp (see Diagram 4.2).

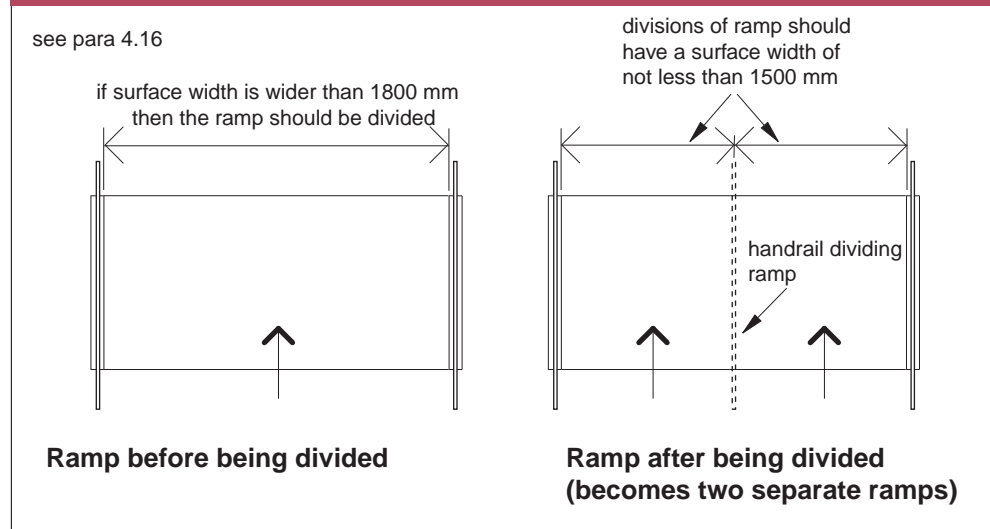
**Diagram 4.2 Dividing wide ramps**

### Construction of ramps

- 4.17 The surface of a ramp **should** –
- be firm;
  - reduce the risk of slipping; and
  - be distinguishable, through suitable visual contrast, from that of its landings.

A ramp and its landings **should** have similar surface frictional characteristics.

- 4.18 A ramp **should** have a raised kerb on any open side (except where it would obstruct normal use). The raised kerb **should** –
- be not less than 100 mm high; and
  - be distinguishable, through suitable visual contrast, from that of the surface of the ramp and landings.

### Landings

Wheelchair users need adequate space to stop on landings, to open and pass through doors without having to reverse into circulation routes or to face the risk of rolling back down slopes.

- 4.19 A landing **should** be provided at the top and bottom of a ramp.
- A landing **should** be level, however, it may have a gradient along its length not steeper than 1 in 60.

The unobstructed length of a landing **should** be not less than 1200 mm. Where a landing is between two ramps, it **should** have an unobstructed length of not less than 1500 mm.

- 4.20 Where the ramped access **or circulation route** consists of three or more ramps, the intermediate landings between each ramp **should** have an unobstructed length of not less than 1800 mm and a surface width of not less than 1800 mm.

- 4.21 Where a ramp does not have a clear line of sight between its top and bottom landings, it **should** be divided into two ramps such that there is a clear line of sight between the intermediate landing and the top and bottom landings. The intermediate landing **should** have an unobstructed length of not less than 1800 mm, and a surface width of not less than 1800 mm. This will allow enlarged landings to be used as passing places.

### **Headroom**

- 4.22 Ramps and associated landings **should** have a clear headroom of not less than 2000 mm over the length and width of the ramp.
- Headroom is measured vertically from the slope of the ramp and the level of the landing (see Diagram 4.1).

### **Handrails**

- 4.23 A ramp or ramps and landings **should** have a suitable continuous handrail on each side complying with the provisions of paragraphs 3.39 to 3.43.
- 4.24 A handrail **should** be at a height measured vertically of –
- (a) not less than 900 mm and not more than 1000 mm above the surface of a ramp; and
  - (b) not less than 900 mm and not more than 1100 mm above the level of a landing.
- 4.25 To give warning of the presence of a change in level a handrail **should** extend horizontally for a distance of not less than 300 mm along the top and bottom landings of a ramp except at an intermediate landing that is not more than 1800 mm in length where it **should** extend the full length of the landing.

## Section 5 Guarding

### General

- 5.1 Paragraphs 5.2 to 5.4 do not apply to –
- (a) guarding to a spiral or helical stair in a dwelling;
  - (b) guarding to a stair or a fixed ladder, in a building other than a dwelling, providing access solely for the purpose of maintenance; and
  - (c) a vehicle barrier.

### Design of guarding

- 5.2 The design of guarding **should** be such as to minimise the risk of people falling, and of rolling, sliding or slipping through gaps in a barrier.

A wall, glazing, parapet, balustrade or similar construction may serve as guarding.

A sunken area next to a building is an area adjoining the building and includes a light well, access to a basement and similar areas. Guarding **should** be provided to that part of a sunken area which is within 3 m of the building.

- 5.3 The height of guarding **should** be measured vertically from the level of a floor or landing, the surface of a ramp or the pitch line of a flight.

However, the top of a portion of any balustrade guarding a landing at the top of a flight or ramp may be continuous with, and at the same angle as, the top of a balustrade guarding that flight or ramp.

- 5.4 Guarding which is provided at the locations given in Table 5.1 column (1) **should** be –
- (a) of a height not less than that given in column (2); and
  - (b) capable of resisting the horizontal force given in column (3) applied at a height of 1100 mm irrespective of the actual height of the guarding (see Diagram 5.1).

### Diagram 5.1 Guarding

see para 5.4

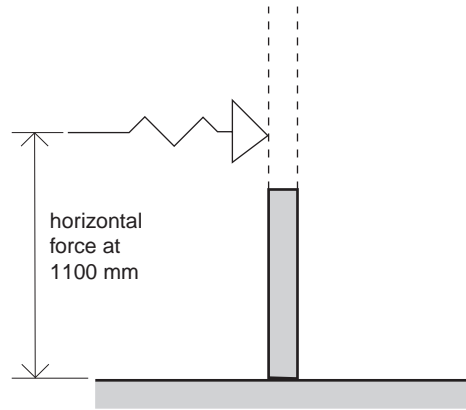

<b>Table 5.1 Minimum height and strength of guarding</b>		
Location of guarding  (1)	Minimum height+  (mm) (2)	Minimum horizontal force/metre run  (kN/m) (3)
<b>1 Dwellings</b>		
(a) guarding a flight, ramp, landing or floor within a dwelling	900*	0.36
(b) guarding an external flight or ramp	900	0.74
(c) guarding a level for the purpose of maintenance	1100	0.36
(d) guarding not described in (a) to (c)	1100	0.74
<b>2 Retail buildings</b>		
(a) guarding a flight or ramp	900	1.50
(b) guarding a level for the purpose of maintenance	1100	0.36
(c) guarding not described in (a) or (b)	1100*	1.50
<b>3 Other buildings</b>		
(a) guarding a flight or ramp where crowd loading will not occur	900	0.74
(b) guarding a flight or ramp where crowd loading† will occur	900	3.00
(c) guarding not described in (b) where crowd loading† will occur	1100 *	3.00
(d) guarding a floor immediately in front of fixed seating	800	1.50
(e) guarding a level for the purpose of maintenance	1100	0.36
(f) guarding not described in (a) to (e)	1100 *	0.74
<b>Notes</b>		
+		
In the case of a flight or ramp the height shall be measured from the pitch line of a flight or the surface of a ramp.		
*		
This may be reduced to 800mm at openable windows or glazing at changes of level. The glazing may be designed to act as guarding, in which case separate guarding would not be required.		
†		
Crowd loading will occur in parts of buildings where people assemble in large numbers such as theatres, discotheques, cinemas, sports halls, assembly halls, shopping malls and similar areas.		

### **Infill panels**

- 5.5 Where infill panels are provided they **should** be designed and constructed in accordance with the relevant clauses of BS 6180:1999.
- 5.6 Where a building or part of a building is likely to be used by children under 5 years of age the guarding **should** be constructed so that a 100 mm diameter sphere cannot pass through any opening in it other than a triangular opening formed by a tread, a rise and the bottom edge of the guarding if that bottom edge is not more than 50 mm above the pitch line. The guarding shall **should** also be constructed so that a child cannot readily climb up it.

### **Guarding of spiral or helical stairs in a dwelling**

- 5.7 In a dwelling, guarding to a spiral or helical stair should be designed and constructed in accordance with BS 5395-2: Stairs, ladders and walkways. Code of practice for the design of helical and spiral stairs.

### **Stair or fixed ladders**

- 5.8 Guarding to a stair or a fixed ladder in a building other than a dwelling providing access solely for the purpose of maintenance should be designed and constructed in accordance with either BS 5395-3: Stairs, ladders and walkways. Code of practice for the design of industrial type stairs, permanent ladders and walkways or BS 4211: Specification for permanently fixed ladders

### **Vehicle barriers**

- 5.9 In a building where vehicles have access to a floor, roof or circulation ramp, guarding should be provided to any edge of such area that is above the level of any adjacent floor, ground or route for vehicles.

Such guarding should –

- (a) not present a hazard e.g. by containing projections on the impact face of the barrier; and
- (b) be designed and constructed in accordance with Annex B of BS EN 1991-1-1:2002.

## Section 6 Vehicle loading bays

### General

#### Loading bays

- 6.1 A loading bay **should** be provided with at least one exit point from the lower level (preferably near the centre of the rear wall).
- 6.2 A wide loading bay (with space for 3 or more vehicles) **should** be provided with at least –
- (a) two exit points, one at each side; or
  - (b) an exit point and a refuge,
- which people can use to avoid being struck or crushed by a vehicle (see Diagram 6.1).

Diagram 6.1 Wide loading bays

see para 6.2

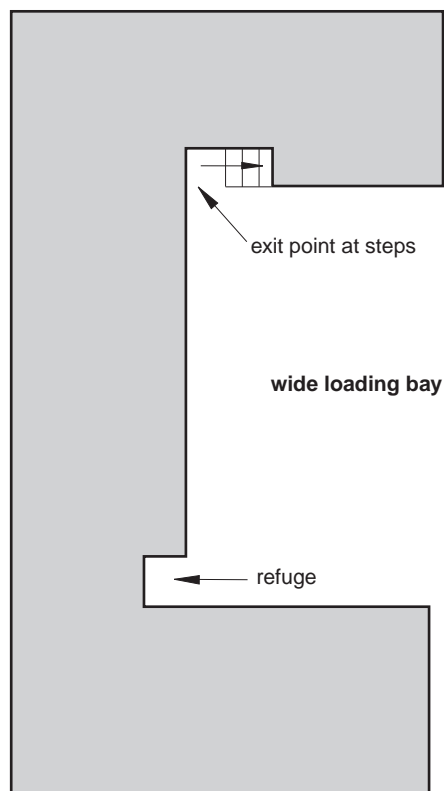

## Section 7 Protection against impact from and trapping by doors

### General

7.1 A door or gate –

- (a) across a main route of travel; or
- (b) which can be pushed open from either side,

should have, towards the leading edge of the door leaf, zones of visibility as shown in Diagram 7.1.

7.2 Any side panel that is more than 450 mm wide and is adjacent to a door or gate, that is required by paragraph 7.1 to have zones of visibility, should also have zones of visibility (see Diagram 7.1).

Diagram 7.1 Zones of visibility

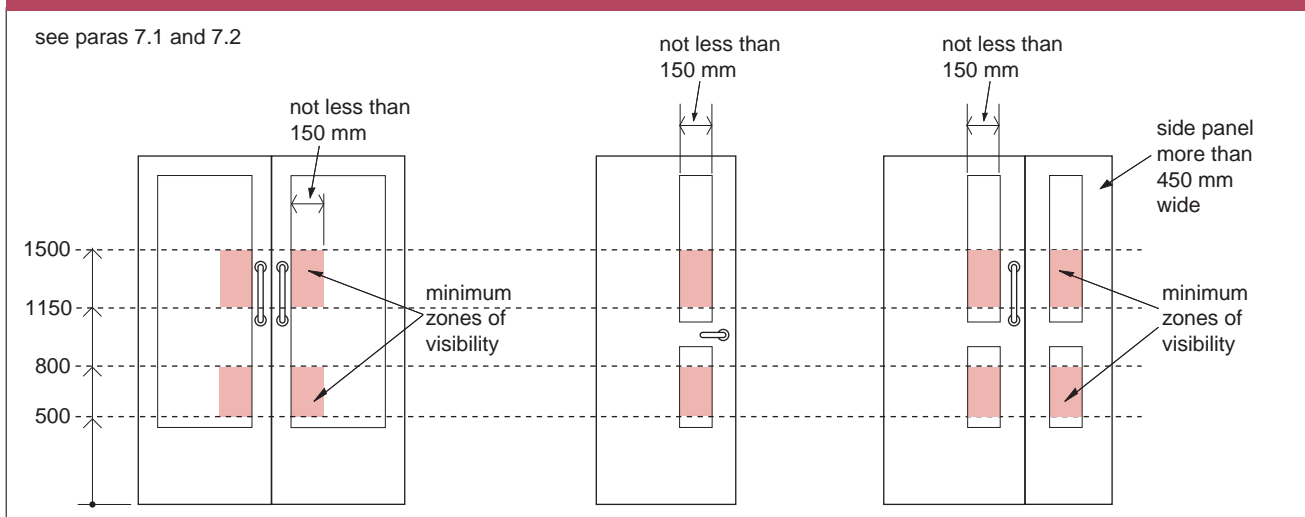

7.3 A door or gate that slides or opens upwards shall should have a device to stop it falling in a way that may cause injury.

7.4 A power operated door or gate designed and constructed for vehicular traffic shall should have –

- (a) a pressure sensitive edge or other suitable device, which operates the power switch to prevent users being caught or trapped;
- (b) a readily identifiable and accessible stop switch; and
- (c) provision for manual or automatic opening in the event of a power failure.

7.5 A power operated door or gate designed and constructed for pedestrian use shall should –

- (a) incorporate a safety stop or door re-activating device to prevent the door striking a person passing through if the door begins to close; and
- (b) revert to manual control or fail safe in the open position in the event of a power failure.

## Section 8 Protection from collision with open windows, skylights or ventilators

### General

8.1 Where any part of a window, skylight or ventilator, when open, could project more than 100 mm horizontally into a space less than 2000 mm above the ground or floor it **should** be –

- (a) fitted with a suitable device to restrict the projection in normal use to not more than 100 mm; or
- (b) marked by a suitable feature such as –
  - (i) a barrier or rail not less than 1100 mm high;
  - (ii) a high relief surface; or
  - (iii) a landscape feature,

which extends to at least the maximum projection of the window, skylight or ventilator (see Diagram 8.1).

8.2 In rooms or spaces used solely for maintenance of the building and access to those rooms or spaces is infrequent, it may be appropriate only to highlight any projecting part of a window, skylight or ventilator to make it easier to see.

**Diagram 8.1 Marking by a barrier or high relief surface**

see para 8.1

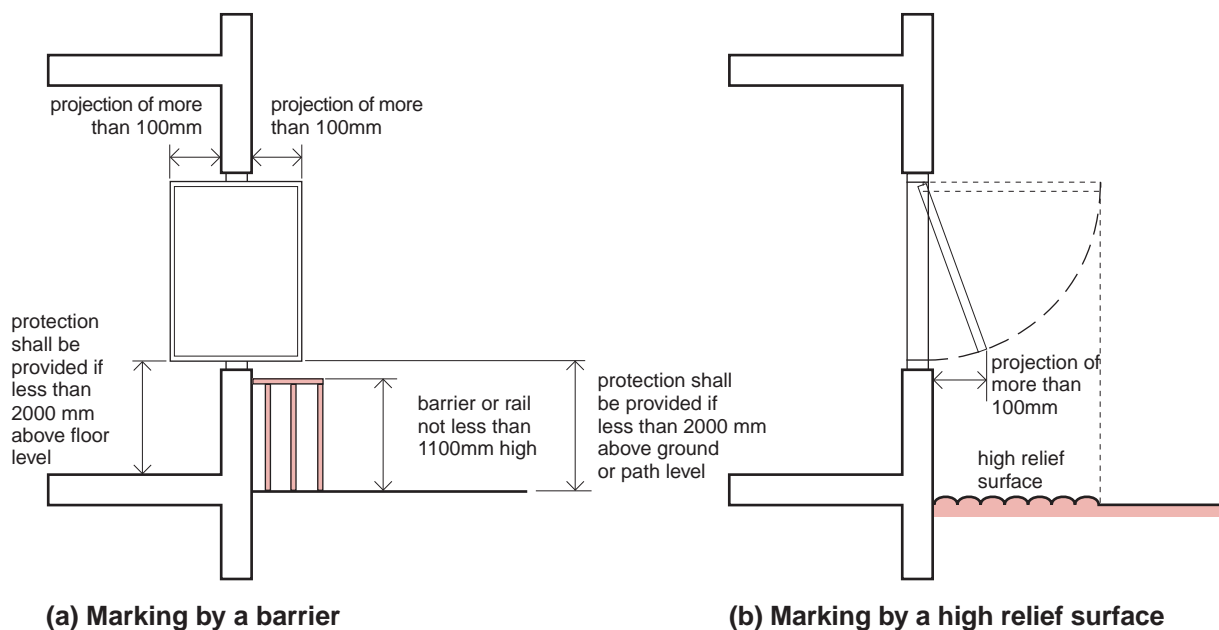

## Appendix A Domestic roofspaces and roofspace conversions

### Roofspaces in dwellings

- A1 It is not recommended that a modern roofspace be used as general storage accommodation as -
- with 270-300mm of cross laid insulation covering the ceiling joists, safety could be compromised;
  - laying boarding could result in the insulation being compressed or removed;
  - timber boarding laid directly on top of insulation will quickly decay due to interstitial condensation;
  - essential roof ventilation could be blocked up;
  - it is not likely that the roof structure will have been designed to take the additional load of stored items.

That being said, evidence suggests that occupiers will tend to use a limited area around the roofspace access area to store infrequently used lightweight household items e.g. suitcases, seasonal decorations and such like.

### Access to roofspaces

- A2 A roofspace to which access is infrequent and solely for maintenance purposes (to permit access to services) is not considered to be a storey therefore, there is no requirement of building regulations to provide a stair.

A dwelling, which has an infrequently accessed roofspace with a limited amount of boarding, either to permit access to services or to allow storage of lightweight household items, is not considered to be a storey in relation to Part H of the building regulations.

### Roofspace conversions in dwellings

- A3 Where work to a roofspace results in the roofspace being put to a different use, regulation H2, along with other relevant Parts of the Building Regulations, must be satisfied.

A roofspace that is converted to provide storage accommodation, i.e. when a room/s is formed, that conversion should be considered to be a storey and regulation H2, along with other relevant Parts of the Building Regulations, applied accordingly.

Where an existing storey is changed to include a habitable room where previously there was no habitable accommodation, work in connection with that change may be necessary to ensure compliance with regulation H2, along with other relevant Parts of the Building Regulations.

## Appendix B Publications referred to

### **BS EN 1991 Eurocode 1: Actions on structures**

Part 1-1: 2002 General actions - Densities, self-weight, imposed loads for buildings

### **BS 4211: 2005 Specification for permanently fixed ladders**

### **BS 5395 Stairs**

Part 2: 1984 Code of practice for the design of helical and spiral stairs

AMD 6076

Part 3: 1985 Stairs, ladders and walkways. Code of practice for the design of industrial type stairs

AMD 14247