



Department of  
**Finance and  
Personnel**  
[www.dfpni.gov.uk](http://www.dfpni.gov.uk)

**Building Regulations (Northern Ireland) 2011**

**Proposed Guidance Edition**

**of**

**Technical Booklet L**

**Combustion appliances and fuel storage systems**

**Draft for Consultation**

**June 2011**

Technical Booklet L

Draft for Consultation

Inside page to front cover

# Contents

page

<b>Introduction</b>	<b>0</b>
<b>Part L Regulations</b>	<b>0</b>
<b>Guidance - Performance and introduction to provisions</b>	<b>0</b>
<b>Section 1      General</b>	<b>0</b>
Definitions	0
<b>Section 2      General provisions for combustion appliances</b>	<b>0</b>
Air supply and ventilation	0
Flues and chimneys	0
Dry lining around fireplace openings	0
Condition of combustion installations at completion	0
Notice plates for hearths and flues	0
Access to combustion appliances for maintenance	0
Detection and warning of the release of carbon monoxide	0
<b>Section 3      Solid fuel burning appliances (including solid biofuel) with a rated heat output up to 50 kW</b>	<b>0</b>
Air supply to appliances	0
Flues and chimneys	0
Hearths	0
Fireplace recesses and prefabricated appliance chambers	0
<b>Section 4      Gas burning appliances with a rated heat input up to 70 kW (net)</b>	<b>0</b>
Gas burning appliances	0
Air supply and ventilation	0
Flues and chimneys	0
Bases for back boilers	0

---

Hearths for gas burning appliances	0
Shielding of appliances	0
<b>Section 5 Oil burning appliances with a rated heat output up to 45 kW</b>	<b>0</b>
Class of oil	0
Appliances fitted in bedrooms, bathrooms and shower rooms	0
Air supply and ventilation	0
Flues and chimneys	0
Shielding of oil fired appliances	0
<b>Section 6 Liquid fuel storage and supply</b>	<b>0</b>
Oil storage installations	0
Liquefied Petroleum Gas (LPG) storage installations	0
<b>Appendix A Inspection and testing of flues, chimneys and fluepipes</b>	<b>0</b>
<b>Appendix B European chimney designations</b>	<b>0</b>
<b>Appendix C Assessing air permeability of older dwellings in relation to permanent ventilation requirements</b>	<b>0</b>
<b>Appendix D Publications referred to</b>	<b>0</b>

# Introduction

## Technical Booklets

### Purpose of Technical Booklets

This Technical Booklet is one of a series that has been prepared by the Department of Finance and Personnel (the Department) for the purpose of providing practical guidance with respect to the technical requirements of the Building Regulations (Northern Ireland) 2011 (the Building Regulations).

Technical Booklets give practical guidance for most of the more common building situations. If this guidance is followed there will be a presumption of compliance with the requirements of the Building Regulations covered by the guidance. For example, if one particular case is unusual in some way, then 'normal' guidance may not be applicable. It is also important to note that there may be alternative ways of achieving compliance with the relevant requirements. There is therefore no obligation to follow the methods or comply with the standards set out in a Technical Booklet if you prefer to meet the requirements in some other way.

## This Technical Booklet

### Requirements

The guidance contained in this Technical Booklet relates only to the requirements of regulations L2, L3, L4, L5, L6, L7 and L8. Regulation L9 is a prescriptive regulation which does not require guidance to aid compliance. The work will also have to comply with all other requirements of the relevant Building Regulations.

### Diagrams

The diagrams in this Technical Booklet supplement the text. They do not show all the details of construction and are not intended to illustrate compliance with any other requirement of the Building Regulations. They are not necessarily to scale and should not be used as working details.

### British Standards and European Technical Specifications

The Building Regulations are made for the following specific purposes: securing the health, safety, welfare and convenience of people; furthering the conservation of fuel and power; furthering the protection and enhancement of the environment; and promoting sustainable development. Standards and technical approvals are relevant guidance to the extent that they relate to these purposes. However, they may also address other aspects of performance such as serviceability, or aspects which although they relate to health and safety are not covered by the Building Regulations.

In this introduction and throughout this Technical Booklet any reference to a British Standard shall be construed as a reference to –

- (a) a British Standard or British Standard Code of Practice;

- (b) a harmonised standard or other relevant standard of a national standards body of any Member State of the European Economic Area;
- (c) an international standard recognised for use in any Member State of the European Economic Area;
- (d) any appropriate, traditional procedure of manufacture of a Member State of the European Economic Area which has a technical description sufficiently detailed to permit an assessment of the goods or materials for the use specified; or
- (e) a European Technical Approval issued in accordance with the Construction Products Directive,

provided that the proposed standard, code of practice, specification, technical description or European Technical Approval provides, in use, equivalent levels of safety, suitability and fitness for purpose as that provided by the British Standard.

The Department intends from time to time to review the guidance in its Technical Booklets to reflect emerging European harmonised standards. Where a national standard is to be replaced by a European harmonised standard, there will be a co-existence period during which either standard may be referred to. At the end of the co-existence period the national standard will be withdrawn.

### **Products conforming with a European Council Directive**

Any product designed and manufactured to comply with the requirements of a European Council Directive does not have to comply with any other standard or part of a standard, whether British, international or other, which relates to the same characteristic or specific purpose as the EC Directive.

### **CE marked construction products**

Any construction product (within the meaning of the Construction Products Directive) which bears a CE marking shall be treated as if it satisfied the requirements of any appropriate **British Standard, British Standard Code of Practice or British Board of Agrément Certificate** relating to such a product, where the CE marking relates to the same characteristic or specific purpose as the **Standard, Code of Practice or Certificate**.

(It is the intention of the Department to review this Introduction to recognise the implementation of new arrangements regarding construction products and CE marking under Regulation (EU) No 305/2011 which will come fully into effect on 1 July 2013.)

### **Named standards**

Where this Technical Booklet makes reference to a named standard, the relevant version of the standard is the one listed in Appendix D. However, if this version has been replaced or updated by the issuing standards body, the new version may be used as a source of guidance provided that it continues to address the relevant requirements of the Building Regulations.

### **Materials and workmanship**

Any work to which a requirement of the Building Regulations applies must, in accordance with Part B of the Building Regulations, be carried out with suitable materials and in a workmanlike manner. You will find guidance in relation to this in Technical Booklet B (Materials and workmanship).

## Interaction with other legislation

### **The Workplace (Health, Safety and Welfare) Regulations (Northern Ireland) 1993**

The Workplace (Health, Safety and Welfare) Regulations (Northern Ireland) 1993 SR 1993 No.37 (Workplace Regulations) contain some requirements which affect building design. The main requirements are now covered by the Building Regulations, but for further information see – The Workplace Regulations and the Workplace Health, Safety and Welfare Approved Code of Practice and Guidance (ISBN 0-33711222-3) published by TSO.

The Workplace Regulations apply to the common parts of flats and similar buildings if people such as cleaners, wardens and caretakers are employed to work in these common parts. Where the requirements of the Building Regulations that are covered by this Part do not apply to dwellings, the provisions may still be required in the situations described above in order to satisfy the Workplace Regulations.

### **The Clean Air (Northern Ireland) Order 1981**

Under the Clean Air (Northern Ireland) Order 1981 a district council may declare the whole or part of a district of the council to be a smoke control area. It is an offence to emit smoke from a chimney of a building, from a furnace or from any fixed boiler if located in a designated smoke control area unless an authorised fuel was used. It is also an offence to acquire an 'unauthorised fuel' for use within a smoke control area unless it is used in an 'exempt' appliance ('exempted' from the controls which generally apply in the smoke control area).

Authorised fuels are fuels which are authorised under the Clean Air (Northern Ireland) Order. These include inherently smokeless fuels such as gas, electricity and anthracite together with specified brands of manufactured solid smokeless fuels. These fuels have passed tests to confirm that they are capable of burning in an open fireplace without producing smoke.

Exempt appliances are appliances (ovens, wood burners, boilers and stoves) which have been exempted by the Clean Air (Northern Ireland) Order. These have passed tests to confirm that they are capable of burning an unauthorised or inherently smoky solid fuel without emitting smoke.

### **Gas Safety (Installation and Use) Regulations (Northern Ireland) 2004**

All combustion installations must be accommodated in ways that meet the requirements of the Building Regulations. However gas installations also have to comply with the Gas Safety (Installation and Use) Regulations (Northern Ireland) 2004 which require professional work to be undertaken by a member of a class of persons approved by the Health and Safety Executive Northern Ireland (HSENI).

The Gas Safety (Installation and Use) Regulations (Northern Ireland) 2004 cover the safe installation of gas fittings, appliances and flues. The following paragraphs give an outline of some of the main requirements of those Regulations but for further information reference should be made to the Health and Safety Commission's Approved Code of Practice and Guidance L56.

The Gas Safety (Installation and Use) Regulations (Northern Ireland) 2004 require that –

- (a) gas fittings, appliances and gas storage vessels must only be installed by a person with the required competence;
- (b) any person having control to any extent of gas work must ensure that the person carrying out that work has the required competence; and
- (c) any gas installation business, whether an employer or self-employed, must be a member of a class of persons approved by the HSENI.

### **The Gas Appliances (Safety) Regulations 1995**

The Gas Appliances (Safety) Regulations 1995 require that particular combinations of appliance, flue box (where required) and flue must be selected from those stated in the manufacturer's instructions as having been shown to be safe by a Notified Body.

### **Control of Oil Pollution**

The control of pollution of groundwater and waterways within Northern Ireland is currently covered by The Groundwater Regulations (Northern Ireland) 2009 and The Water (Northern Ireland) Order 1999.

This legislation is enhanced by The Control of Pollution (Oil storage) Regulations (Northern Ireland) 2010 which covers above ground oil storage installations, on premises used wholly or mainly as one or more private dwellings, storing more than 3,500 litres of oil. It will also cover any industrial, commercial and institutional sites storing more than 200 litres of oil.

### **Liquefied Petroleum Gas (LPG) Installations**

LPG installations are controlled by legislation enforced by the HSENI or its agents. Factors that determine the amount of building work necessary for a LPG storage installation to comply include its capacity, whether or not tanks are installed above or below ground and the nature of the premises they serve. LPG storage installations shall be shown to comply with the legislation by constructing it in accordance with:

- (a) LPGA Code of Practice 1: Parts 1 to 4; or
- (b) LPGA Code of Practice 24: Use of LPG Cylinders: Part 1: The use of propane cylinders at residential premises where applicable.

# Part L Regulations

It should be noted that the following regulations are the requirements of Part L of the Building Regulations (Northern Ireland) 2011. All parts of the regulations must be read in conjunction with Part A: Interpretation and general of those regulations.

---

## PART L

---

### Combustion appliances and fuel storage systems

---

#### L1 Application and interpretation

- (1) Any provision in regulations L2, L3, L4, L5, L6 and L9 which applies to a combustion appliance, shall also apply where solid fuel is intended to burn directly on a hearth without the installation of any appliance.
- (2) Regulation L4 shall not apply to a combustion appliance designed solely for cooking purposes.
- (3) Regulation L7 shall only apply to a liquid fuel storage tank and connecting pipework located outside the building, which serves a fixed combustion appliance within the building and which is—
- (a) a fixed oil storage tank with a capacity greater than 90 litres; or
  - (b) a fixed liquefied petroleum gas storage tank with a capacity greater than 150 litres.
- (4) Regulation L8 shall only apply to a fixed oil storage tank, which serves a dwelling and to which any one of the following applies—
- (a) it has a capacity of more than 2500 litres but less than 3500 litres;
  - (b) it is located within 10 m of inland freshwaters or coastal waters;
  - (c) it is located within 50 m of a source of potable water, such as a well, bore-hole or spring;
  - (d) it is located where spilled oil from the installation could reach the waters in (b) or (c) by running across hard ground;
  - (e) it is located where spillage could run into an open drain or loose fitting manhole cover; or
  - (f) it is located where the tank vent pipe outlets cannot be seen from the intended filling point.
- (5) In this part—
- COMBUSTION APPLIANCE** means a fixed appliance (including a cooker) which—
- (a) is designed to burn solid fuel, gas or oil; or
  - (b) is an incinerator.

#### L2 Air supply

A combustion appliance shall be so installed as to receive a sufficient supply of air to ensure the safe and efficient operation of the combustion appliance and any connected flue.

### **L3 Discharge of products of combustion**

A combustion appliance shall be so installed and any connected flue-pipe, flue or chimney shall be so constructed and installed as to ensure that the products of combustion are discharged to the external air without causing a hazard to the health of any person.

### **L4 Warning of release of carbon monoxide**

Where a combustion appliance is installed in a dwelling, reasonable provision shall be made to detect and give warning of the release of carbon monoxide at levels harmful to people.

### **L5 Protection of people and buildings**

(1) A combustion appliance shall be so installed and any connected flue-pipe, flue or chimney shall be so constructed and installed as to ensure that their use shall not cause—

- (a) burns to any person; or
- (b) damage to a building by heat or fire.

(2) A hearth or fireplace recess shall be so designed and constructed as to prevent damage to a building by heat or fire as a result of the operation of a combustion appliance installed in it or on it.

### **L6 Provision of information**

Where a hearth, fireplace, flue or chimney is provided or extended, a durable notice containing information on its performance capabilities shall be affixed to a suitable place in the building for the purpose of enabling a compatible combustion appliance to be safely connected to that hearth, fireplace, flue or chimney.

### **L7 Protection of liquid fuel storage tanks**

Reasonable provision shall be made to ensure that a liquid fuel storage tank and connecting pipework is so constructed and separated from adjacent buildings and the boundary of the premises as to reduce to a reasonable level the risk of the fuel contained inside it igniting in the event of a fire occurring in adjacent buildings or premises.

### **L8 Protection against pollution**

An oil storage tank and connecting pipework shall be so constructed and protected as to minimise the risk of an escape of oil causing pollution to the environment.

### **L9 Prevention of smoke emission**

A combustion appliance installed in a building for the purpose of heating or cooking, and which discharges its combustion products to the external air shall be capable of, or readily adaptable to, the burning of fuel smokelessly, unless it is—

- (a) a furnace which complies with Article 5 of the Clean Air (Northern Ireland) Order 1981 (a) (which requires that new furnaces shall so far as practicable be smokeless); or
- (b) an appliance of a class exempted conditionally or unconditionally from the provisions of Article 17 of the Clean Air (Northern Ireland) Order 1981 (which relates to smoke control areas) by any order for the time being in force under paragraph (7) of that Article.

---

(a) S.I. 1981 No.158(N.I. 4)

# Guidance - Performance and introduction to provisions

## General

This Technical Booklet gives guidance on how to satisfy the requirements of Part L. Although Part L applies to the accommodation of any combustion installation and liquid fuel storage system within the limits as applied by regulation L1, the guidance in this Technical Booklet has been prepared mainly with domestic type installations in mind.

For installations subject to the requirements of Part L but outside the provisions of this Technical Booklet, such as incinerators or installations with higher ratings than those given, specialist guidance may be necessary. However, some larger installations may be shown to comply by adopting the relevant recommendations to be found in the Chartered Institution of Building Services Engineers (CIBSE) Guide B and practice standards produced by the British Standards Institution (BSI) and the Institution of Gas Engineers & Managers (IGEM).

## Combustion appliances and provision of information

### Performance

In the Department's view the requirements of regulations L2, L3, L4, L5 and L6 will be met if the building provides for the safe accommodation of combustion appliances which –

- (a) enables the admission of sufficient air for –
  - (i) the proper combustion of fuel and the operation of flues; and
  - (ii) the cooling of appliances where necessary;
- (b) enable normal operation of appliances without the products of combustion becoming a hazard to health;
- (c) incorporate an appropriate means of detection and warning of a release of carbon monoxide;
- (d) enable normal operation of appliances without their causing danger through damage by heat or fire to the fabric of the building;
- (e) have been inspected and tested to establish suitability for the purpose intended; and
- (f) have been labelled to indicate performance capabilities.

### Introduction to provisions in Section 2

The guidance in Section 2 sets out the general provisions for combustion appliances that should be met, specifically air supply, flues, access for maintenance, and detection and warning of the release of carbon monoxide.

### Introduction to provisions in Section 3

Section 3 gives guidance on the installation of a solid fuel burning combustion appliance in relation to specific provisions for air supply, flues, chimneys and hearths.

## **Introduction to provisions in Section 4**

Section 4 sets out provisions that should be met for gas burning appliances specifically air supply, flued and flueless appliances, hearths and shielding.

## **Introduction to provisions in Section 5**

The guidance in Section 5 is to ensure that where an oil burning appliance is installed specific provision of air supply, flues, chimneys, hearths and shielding is made.

## **Alternative approach**

The requirements of regulations L2, L3 and L5 may also be met by adopting the relevant recommendations in the publications listed below to achieve an equivalent level of performance to that obtained by following the guidance in this Technical Booklet:

BS 8303-1:1994

BS 5440-Part 2:2009

BS 5410-1:1997

## **Protection of liquid fuel storage tanks and protection against pollution**

### **Performance (Regulation L7)**

In the Department's view the requirements of regulation L7 will be met where oil and LPG fuel storage installations, including the pipework connecting them to the combustion appliances in the buildings they serve, are located and constructed so that they are reasonably protected from fires which may occur in buildings within the boundary or where the installation is close to the boundary, either protected or separated from the boundary of the site.

### **Performance (Regulation L8)**

In the Department's view the requirements of regulation L8 will be met if an oil storage tank/s serving a dwelling –

- (a) incorporates secondary containment; and
- (b) has any ancillary equipment and pipework connecting it to a combustion appliance reasonably resistant to physical damage and corrosion.

## **Introduction to provisions in Section 6**

Section 6 gives guidance –

- (a) on the measures to be taken to protect an oil or LPG fuel storage installation –
  - (i) from a fire in the building it serves; and
  - (ii) where the installation is located adjacent to the boundary of the site, and

(b) on the construction of oil storage tanks.

**Alternative approach**

The requirements for an oil storage tank may also be met by adopting the relevant recommendations in BS 5410-1:1997 to achieve an equivalent level of performance to that obtained by following the guidance in this Technical Booklet.

## Section 1 General

- 1.1 This Technical Booklet gives provisions which if followed, should comply with the functional requirements of Part L of the Building Regulations and includes the admission of sufficient air into the building to enable the proper combustion of fuels and operation of flues. Technical Booklet K gives guidance on complying with Part K (Ventilation). Part K is concerned with providing adequate ventilation to limit the accumulation of moisture and pollutants which could become a hazard to the health of the users of a building.

### Definitions

- 1.2 In this Technical Booklet the following definitions apply –

**Appliance compartment** – an enclosure specifically constructed or adapted to accommodate one or more gas or oil-fired appliances.

**Balanced compartment** – a method of installing an open-flued appliance into a compartment which is sealed from the remainder of the building and whose ventilation is so arranged in conjunction with the appliance flue as to achieve a balanced flue effect.

**Balanced flue appliance** – a type of room-sealed appliance that draws its combustion air from a point outside the building adjacent to the point at which the combustion products are discharged, the inlet and outlet being so disposed that wind effects are substantially balanced.

**Boundary** – in relation to a building, the boundary of the land to which the building belongs and such land shall be deemed to include any abutting part of any street, canal or river but only up to the centre line thereof; and boundary of the premises shall be construed so as to include any such part to the same extent.

**Capacity** (of an oil or gas tank) – the nominal volume of the tank as stated by the manufacturer.

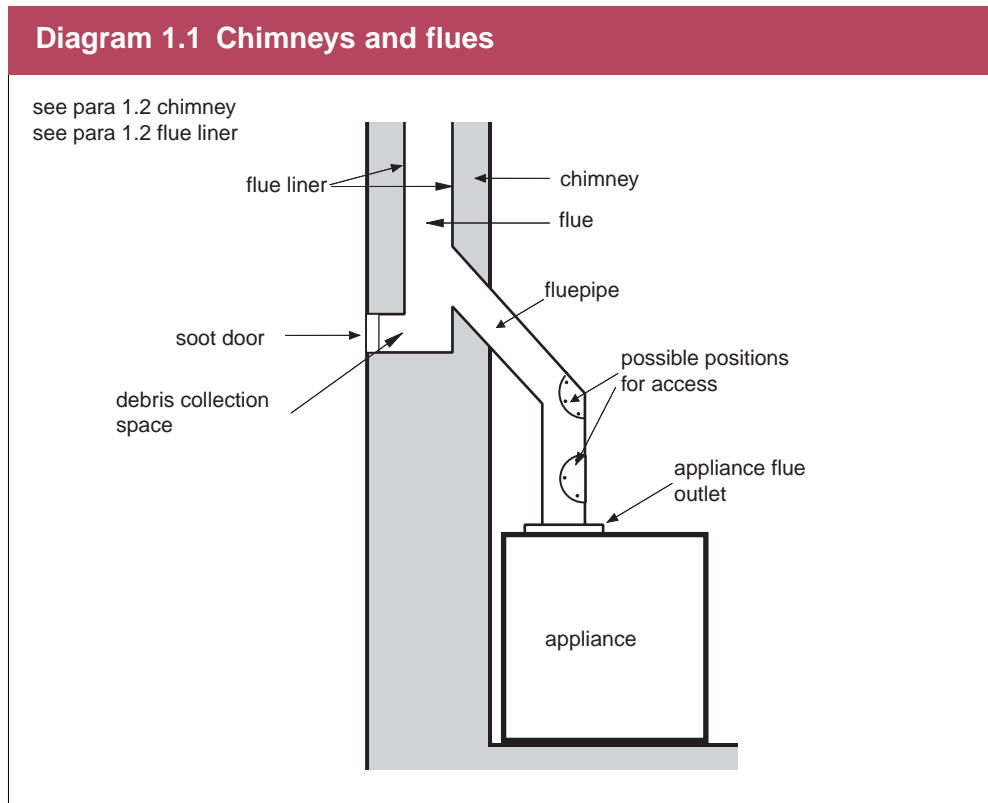

**Chimney** – a structure consisting of a wall or walls enclosing one or more flues (see Diagram 1.1).

**Combustion appliance** means a fixed appliance (including a cooker) which –

- (a) is designed to burn solid fuel, gas or oil; or
- (b) is an incinerator.

**Designation** – BS EN 1443:2003 expresses the performance characteristics of a flue or its components, as assessed in accordance with an appropriate European product standard, by means of a code such as “EN 1234 T400 P1 S W 1 R22 C50”. This code is known as the designation for the flue or its components (see Appendix B).

**Draught break** – an opening formed by a factory-made component into any part of the flue serving an open-flued appliance.

**Draught diverter** – a form of draught break intended to prevent conditions in the main length of flue from interfering with the combustion performance of an open-flued appliance (see Diagram 1.2(a)).

**Draught stabiliser** – a factory-made counter-balanced flap device admitting air to the flue, from the same space as the combustion air, to prevent excessive variations in the draught (see Diagram 1.2(b)).

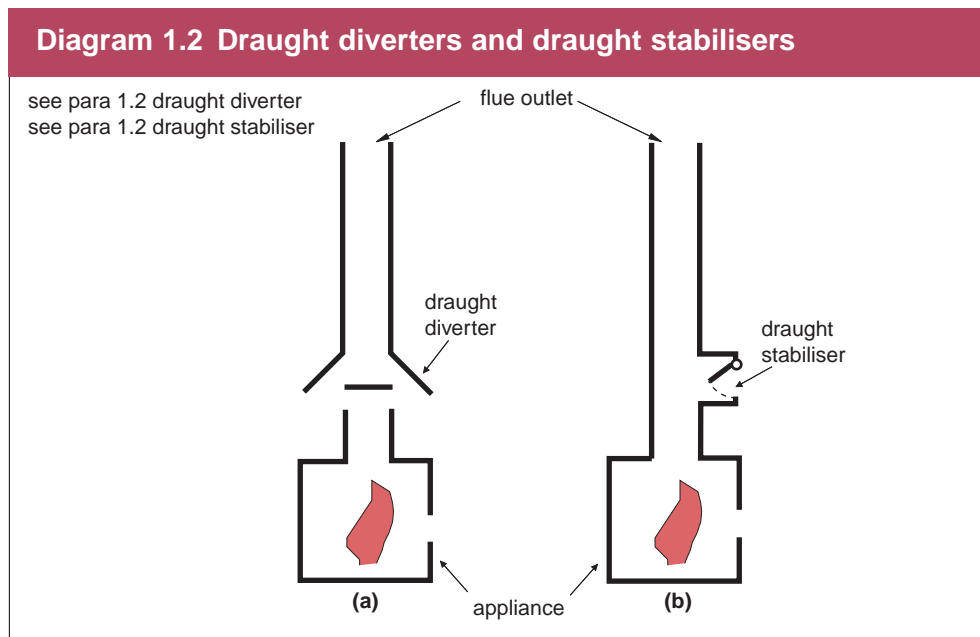

**Equivalent area** (as defined in BS EN 13141-1:2004) – the area of a sharp-edged circular orifice which would pass the same air flow rate at the same applied pressure difference as the product or device being tested. The equivalent area of a simple ventilator will be less than the geometrical free area and for complex products may be significantly less.

**Factory-made metal chimneys** (also known as system chimney) – prefabricated chimneys that are commonly manufactured as sets of components for assembly on site (although they can be supplied as one unit), having the performance appropriate for the intended appliance.

**Fanned draught installation** – the proper discharge of the flue gases depends upon the operation of a fan, which may be separately installed in the flue or may be an integral part of the combustion appliance (see Diagram 1.3).

**Fire compartment** – a building or part of a building comprising one or more rooms, spaces or storeys, constructed to prevent the spread of fire to or from another part of the same building, or an adjoining building. A roof-space above the top storey of a fire compartment is included in that fire compartment.

**Fireplace recess** – a structural opening (sometimes called a builder's opening) formed in a wall or in a chimney breast, from which a chimney leads and which has a hearth at its base (see Diagram 1.4).

**Fire resistance** (of a component or construction) – a measure of its ability to withstand the effects of fire in one or more ways for a stated period of time. Provisions on determination of performance in terms of fire resistance are given in Technical Booklet E (Fire safety).

**Diagram 1.3 Types of installation**

see para 1.2 fanned draught installation  
 see para 1.2 forced draught appliances  
 see para 1.2 flueless appliance  
 see para 1.2 open flued appliance  
 see para 1.2 room sealed appliance  
 see para 1.2 natural draught flue

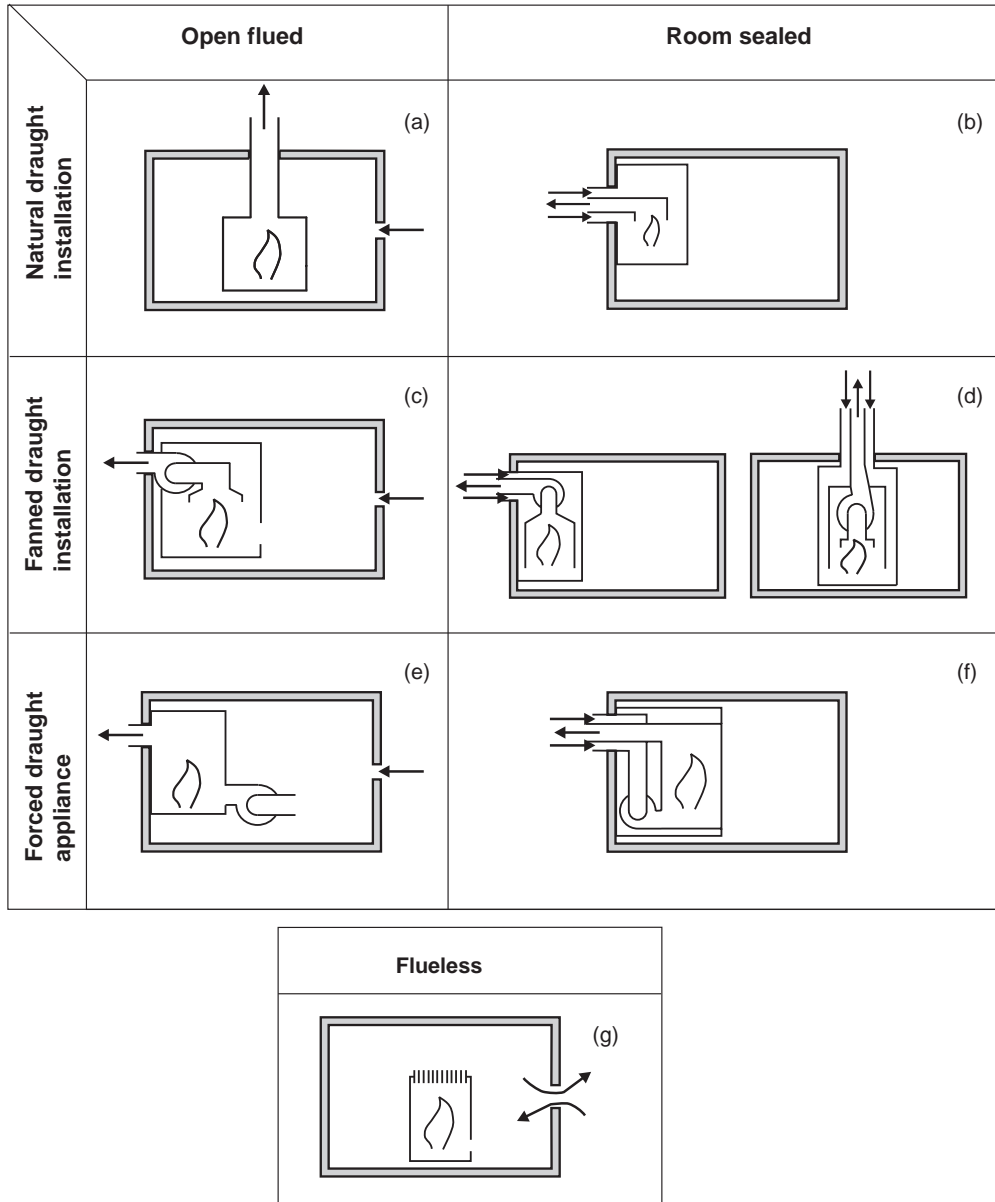

Note: For gas appliances only: CEN CR1749 classifies gas appliances according to their method of evacuating the products of combustion:  
 Type A - Flueless appliances  
 Type B - Open flued  
 Type C - Room sealed

The letters A, B and C are further qualified by numbers to identify the existence and mode of use of fans and draught diverters, as applicable (e.g. B<sub>11</sub> for an open flued natural draught appliance with draught diverter).

## Diagram 1.4 Fireplace recesses

see para 1.2 fireplace recess  
 see para 1.2 natural draught flue  
 see Diagram 3.11

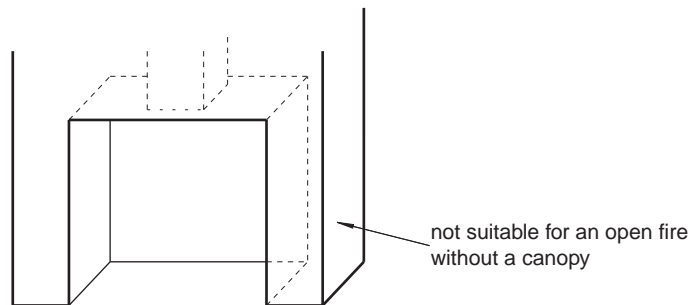

Simple recess suitable for closed appliances such as roomheaters and cookers that are connected to their flues

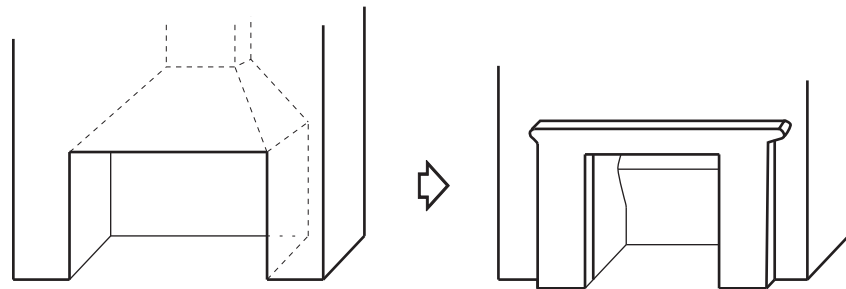

(b) Structural opening prepared to receive an appliance such as a free standing fire basket

Recess comprising structural opening (as (b)) lined to receive an inset open fire and with decorative surround.  
 (See also Diagram 3.12)

**Firewall** – a method of shielding a fuel tank from the thermal radiation from a fire in the adjoining building or boundary.

**Flueblock chimney systems** – a set of factory-made components made from precast concrete, clay or other masonry units that are designed for assembly on site to provide a complete chimney having the performance appropriate for the intended appliance.

**Flue box** – a factory-made unit, usually made of metal, which is similar to a prefabricated appliance chamber except that it is designed to accommodate a gas-burning appliance in conjunction with a factory-made chimney.

**Flueless appliance** – one which is designed to be used without connection to a flue (see Diagram 1.3(g)).

**Flue liner** – the wall of the chimney that is in contact with the products of combustion (see Diagram 1.1), such as a concrete flue liner, the inner liner of a factory-made chimney system or a flexible liner fitted into an existing chimney.

**Flue outlet** – the point at which the products of combustion are discharged from the flue to the outside atmosphere, such as the top of a chimney pot or flue terminal.

**Fluepipe** – a pipe, either single walled (bare or insulated) or double walled, which connects a combustion appliance to a flue in a chimney.

**Forced draught appliances** – an appliance with a fan that provides the combustion air, common in oil-fired and many gas-fired boilers (see Diagram 1.3).

**Hearth** – a base intended to safely isolate a combustion appliance from people, combustible parts of the building fabric and soft furnishings (see Diagram 1.5).

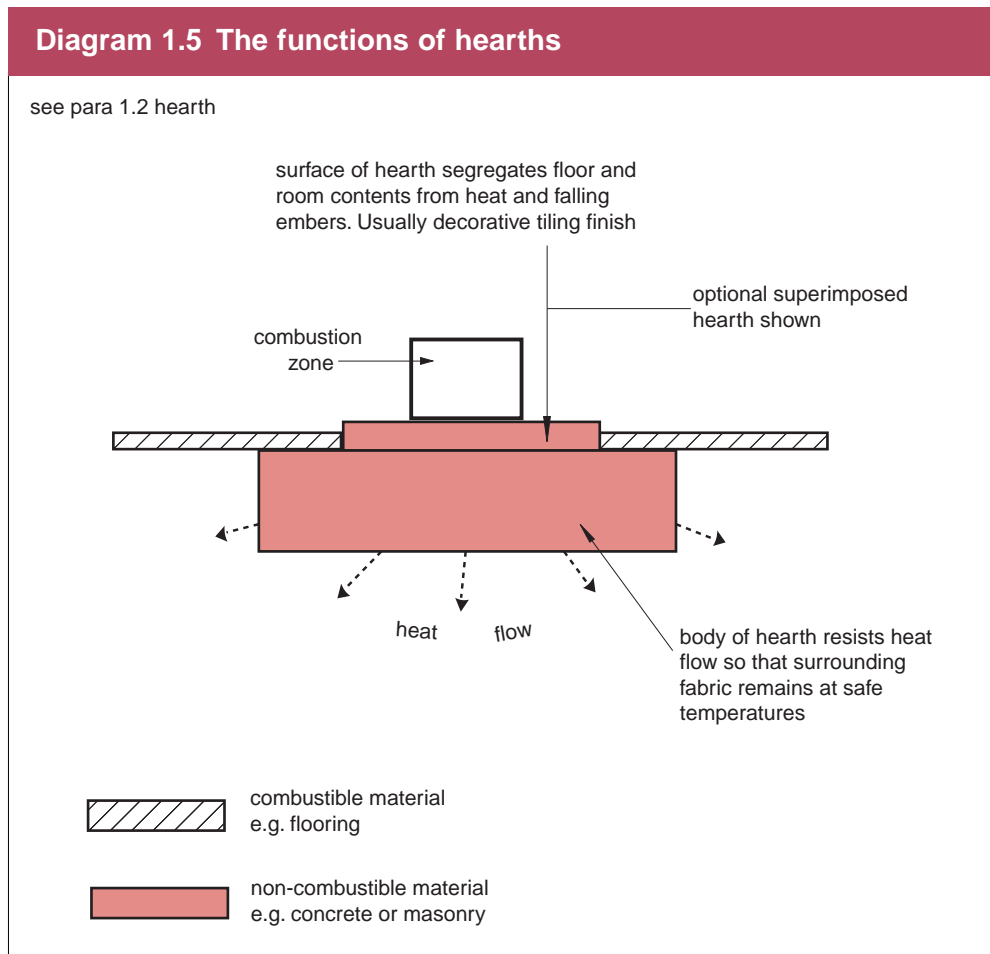

**Natural draught flue** – the combustion products flow into the flue as a result of the buoyancy force produced due to the difference between the temperature of the gases within the flue and the temperature of the ambient air. Draught increases with the height of the flue. Except for those balanced flue appliances which are designed to discharge directly through the wall adjacent to the appliance, a satisfactory natural draught requires an essentially vertical run of flue (see Diagram 1.3 (a) and (b)).

**Non-combustible material** – This is the highest level of reaction to fire performance. A non-combustible material is –

- (a) a material classified as non-combustible in tests following the procedures in BS 476:Part 4:1970;
- (b) a material which when tested to BS 476:Part 11:1982 does not flame nor cause any rise in temperature on either the centre (specimen) or furnace thermocouples; or
- (c) a material classified as Class A1 in accordance with BS EN 13501:2002 Fire classification of construction products and building elements: Part 1: Classification using test data from reaction to fire tests when tested to –
  - (i) BS EN ISO 1182:2002 Reaction to fire tests for building products – Non-combustibility test; and
  - (ii) BS EN ISO 1716:2002 Reaction to fire tests for building products – Determination of the heat of combustion.

Typical examples of such materials to be found in buildings include totally inorganic materials such as concrete, fired clay, ceramics, metals, plaster and masonry containing not more than 1% by weight or volume of organic material. (Use in buildings of combustible metals such as magnesium-aluminium alloys shall be assessed in each individual case).

**Notified Body** – for the purposes of the Gas Appliances (Safety) Regulations (1995), means –

- (a) A body which is approved by the Secretary of State for Trade and Industry as being competent to carry out the required Attestation procedures for gas appliances and whose name and identification number has been notified by him/her to the Commission of the European Community and to other member States in accordance with the Gas Appliances (Safety) Regulations 1995; or
- (b) A body which has been similarly approved for the purposes of the Gas Appliances Directive by another member State and whose name and identification number has been notified to the Commission and to other member States pursuant to the Gas Appliances Directive.

**Open-flued appliance** – one which draws its combustion air from the room or space within which it is installed and which requires a flue to discharge its products of combustion to the outside air (see Diagram 1.3 (a), (c) and (e)).

**Prefabricated appliance chamber** – a set of factory-made pre-cast concrete components designed to provide a fireplace recess to accommodate an appliance such as a stove, and incorporates a gather when used with an open fire.

**Rated heat input** (sometimes shortened to rated input) – for a gas appliance means the maximum heat input rate (kW) at which it can be operated, as declared on the appliance data plate.

**Rated heat output** – for an oil or solid fuel appliance means the manufacturer's maximum declared energy output rate (kW) for the appliance as declared on the appliance data plate.

**Room-sealed appliance** – an appliance with a combustion system that is sealed from the room in which it is located, and which obtains air for combustion, from a ventilated uninhabited space within the building, or directly from the open air outside the building and vents the products of combustion directly to the open air outside the building (see Diagram 1.3 (b), (d) and (f)).

**Separated part** – of a building means a form of compartmentation in which part of a building is separated from another part of the same building by a compartment wall. The wall runs the full height of the part and is in one vertical plane.

**Solid biofuel** – a solid fuel derived from plants and trees. It can include logs, wood chips, wood pellets and other processed plant material.

**Throat** – a contracted part of the flue between a fireplace recess and its chimney (see Diagram 3.5).

## Section 2 General provisions for combustion appliances

### Air supply and ventilation

#### Air supply for combustion appliances

- 2.1 All combustion appliances require the supply of air for combustion and to ensure the proper operation of the flue. A flueless appliance also needs air to ensure that the products of combustion are safely dispersed to the outside air. In some cases, combustion appliances may also require air for cooling control systems and/or to ensure that casings remain safe to touch.
- 2.2 The size of air vent required, which is dependent upon the type of fuel burned, is given in Sections 3, 4 and 5 and is for one combustion appliance only. If a room contains more than one combustion appliance the air supply provisions will have to be increased.

#### Ventilation of appliance compartments

- 2.3 An appliance compartment that encloses an open-flued appliance **should** be provided with an air vent(s) large enough to admit all of the air required for combustion and the proper operation of the flue.
- 2.4 High and low level vents **should** be provided where the combustion appliance requires cooling air and the appliance compartment **should** be large enough to enable the air to circulate effectively.
- 2.5 Where the combustion appliance is to be installed within a balanced compartment special provisions will be necessary. In such circumstances the manufacturer's instructions for the combustion appliance and ventilation system **should** be followed.

#### Ventilation via other rooms or spaces

- 2.6 If a combustion appliance is room-sealed but takes its combustion air from another space in the building, or if a flue has a permanent opening to another space in the building, that space **should** have ventilation openings directly to the outside air.
- 2.7 Where a flued appliance is supplied with combustion air through an air vent(s) that opens into an adjoining room or space, the adjoining room or space **should** have air vent openings of at least the same size directly to the outside air.
- An air vent(s) for a flueless appliance **should** always open directly to the outside air.
- 2.8 Where ventilation is to be provided via a single proprietary assembly the equivalent free area of the air vent **should** be taken to be the manufacturer's value. The manufacturer may call this a free area or equivalent free area (see Diagram 2.1(a)).

- 2.9 Where two or more components are to be used to provide a non-proprietary ventilation assembly, the assembly **should** be kept as simple and smooth as possible. The assembly **should** be taken to have an **equivalent area** equal to that of the component with the smallest **equivalent area** in the assembly.
- 2.10 **The equivalent area stated in the ventilator manufacturer's literature or marked on the air vent should be used whenever it is available, as this can differ considerably from the free area measured at one end of the air vent. When this is not available the equivalent area of a simple ventilator with no internal baffles can be taken as the total unobstructed cross-sectional area, measured in the plane where this area is at a minimum and at right angles to the direction of air flow. For an airbrick, grille or louvre with apertures no smaller than 5 mm, it will be the aggregate free area of the individual apertures as shown in Diagram 2.1.**
- 2.11 Grilles or meshes protecting air vents from the entry of animals or birds **should** have individual aperture dimensions of not less than 5 mm.

## Diagram 2.1 Ventilator free areas

see paras 2.8, 2.9 and 2.10

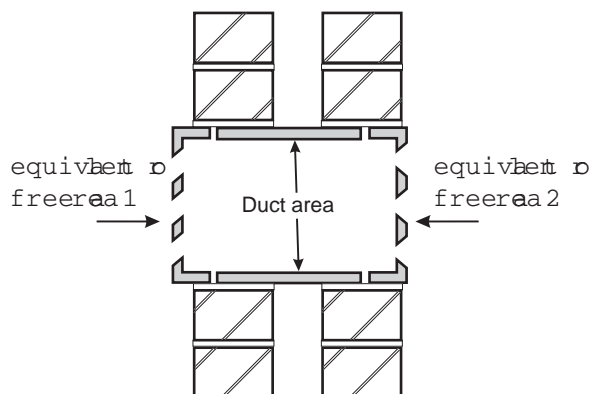

The ventilator area is the smaller of equivalent area 1 or 2 (as declared by the manufacturer), free area 1 or 2 (as measured in (b)) or the duct area.

(a) Ventilator assembled on site from components

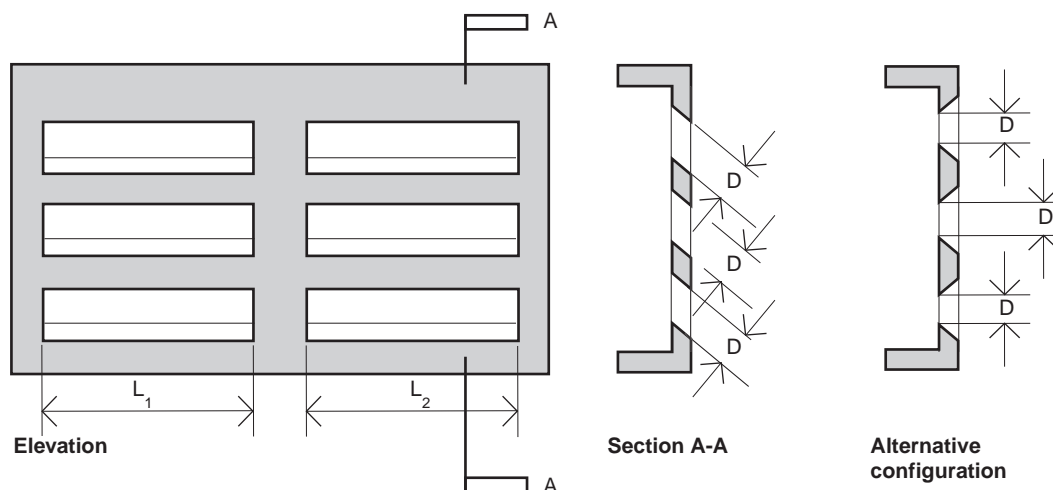

(b) Measuring the free area of components on site -  
 net free area =  $(L_1 + L_2) \times D \times N$   
 (where N = the number of slots)

### Permanently open ventilation of rooms

- 2.12 A room containing an open-flued appliance must receive a continuous supply of air from outside. The volume of air required will depend on the type and rating of the appliance. This will normally mean the installation of permanently open air vents into that room.
- 2.13 A permanently open air vent **should** be non-adjustable and be positioned where it is unlikely to become blocked. It **should** be so installed that the building occupants are not provoked into sealing it against draughts or noise.

It **should** not be positioned in a fire resisting wall other than an external wall that is not part of an external wall shielding a LPG or oil storage tank. A permanently open air vent **should** not be located within a fireplace recess.

- 2.14 A permanently open air vent **should** be sized so that the free area, or the equivalent free area of a more complex design, is sufficient for the appliance to be installed, taking account where necessary of obstructions such as grilles and anti vermin mesh.
- 2.15 Any discomfort from cold draughts can be avoided by placing the air vent close to the appliance, drawing air from other parts of the building or by ensuring a good mix of the incoming cold air by placing the air vent close to the ceiling. (see Diagrams 2.2 and 2.3). In a noisy area, it may be necessary to install proprietary noise attenuated air vents to limit the entry of noise into the building but these **should** not diminish the required air supply. **The location of air vents should not breach the requirements of Part E of the Building Regulations.**

**Diagram 2.2 Examples of perimeter air vents openings**

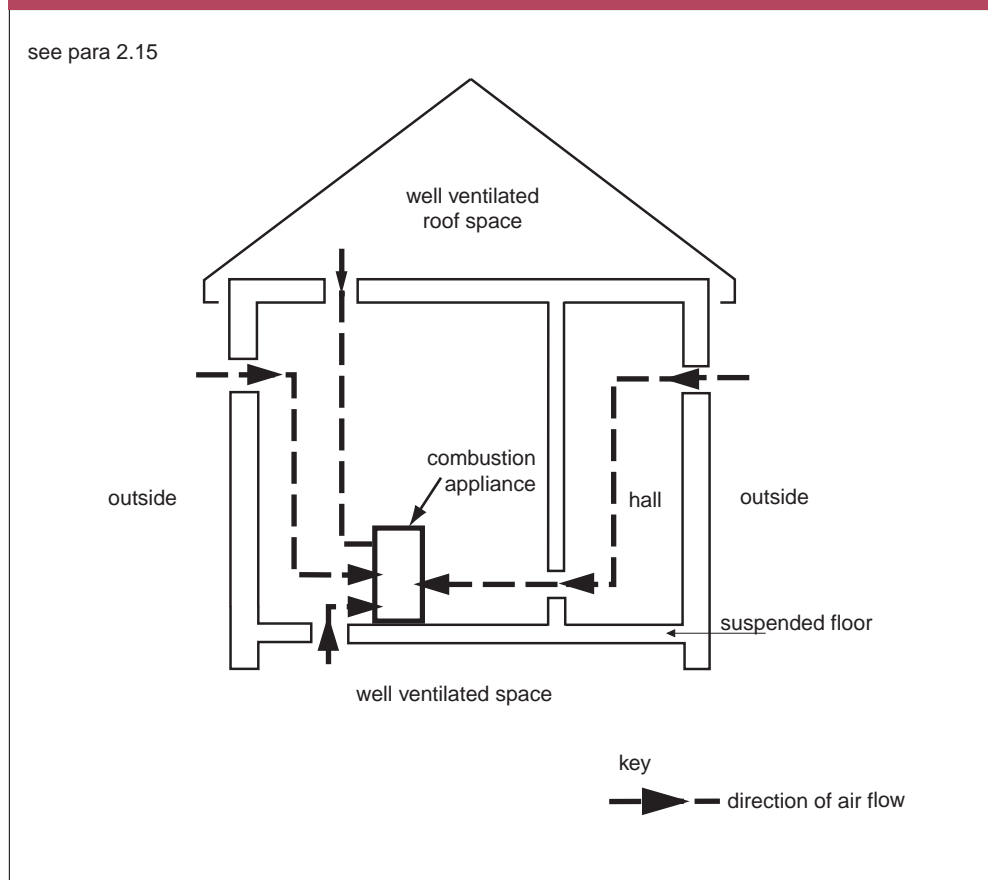
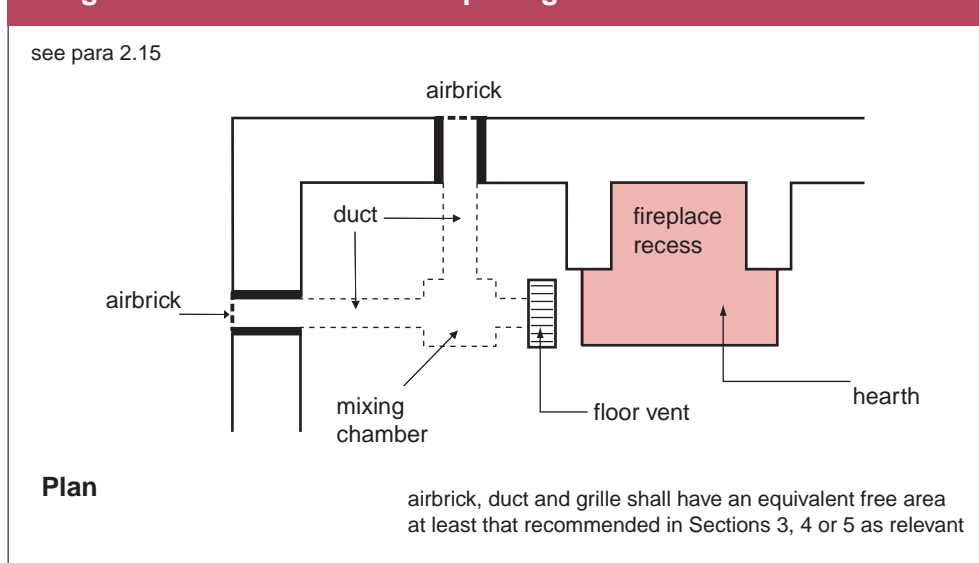

Diagram 2.3 Permanent vent openings in a solid floor



### Interaction of mechanical extract ventilation and open-flued combustion appliances

- 2.16 Extract fans lower the pressure in a building and this can cause the spillage of combustion products from an open-flued appliance.
- 2.17 In a building where it is intended to install an open-flued appliance and an extract fan the combustion appliance **should** operate safely whether or not the fan is running. To minimise the risk of spillage of flue gas the following provisions **should** apply.
- For a gas appliance – where a room contains an open-flued appliance, the room extract fan rate **should** not exceed 20 litres/second (72 m<sup>3</sup>/hour), and a spillage test as recommended in BS 5440-1:2008 **should** be carried out.
  - For oil appliances – where a room contains an open-flued appliance the extract rate should be limited to 40 litres/second for an appliance with a pressure jet burner and 20 litres/second for an appliance with a vaporising burner. When spillage or flue draught interference is identified, it may be necessary to add additional ventilation to the room or space. A flue draught interference test for oil-fired appliances as described in OFTEC Technical Books 2 and 5 should be carried out.
  - For a solid fuel appliance – a room extract fan **should** not be installed in the same room. **If mechanical extraction is unavoidable then seek specialist advice from a mechanical/services engineer to ensure safe operation of the appliance.**
  - For commercial and industrial installations – specialist advice from a mechanical/services engineer **should** be necessary with regard to the possible need for the interlocking of gas heaters and any mechanical ventilation system.

## Flues and chimneys

### Provision of flues

- 2.18 This Technical Booklet provides **guidance** on how to construct a flue or chimney that serves only one appliance. A flue designed to serve more than one appliance **should** follow the recommendations of BS 5410 Part-1:1997 for oil and BS 5440 Part-1:2008 for gas-fired combustion appliances. Each solid fuel appliance **should** have its own flue.
- 2.19 A combustion appliance, other than a flueless appliance, **should** incorporate or be connected to a suitable flue that discharges to the outside air.

### Condensates in flues

- 2.20 A flue **should** provide satisfactory control of water condensation. This can be achieved by adopting one of the following provisions –
- (a) the flue for a non-condensing combustion appliance **should** be insulated so that flue gas does not condense during normal operation; or
  - (b) the flue for a condensing combustion appliance **should** be lined with components that are impervious to condensates and resistant to corrosion (**BS EN 1443:2003 'W' designation**) avoiding ledges, crevices, etc.

**A condensing combustion appliance should have a suitable drain fitted for the disposal of condensate. Guidance on the disposal of such condensate is given in Technical Booklet N.**

### Construction of masonry chimneys

- 2.21 A new chimney shall be constructed with a flue liner and masonry suitable for the intended application. The following liners are suitable for a solid fuel appliance as well as being generally suitable for other fuels –
- a liner with a performance that is equal to that corresponding to the designation T400 N2 D 3 G, as described in BS EN 1443: 2003, such as –
    - (i) clay flue liners, with rebates or sockets for jointing, meeting the requirements for Class A1 N2 or Class A1 N1 as described in BS EN 1457:2009;
    - (ii) concrete flue liners meeting the requirements for the classification Type A1, A2, B1 or B2 as described in BS EN 1857:2003; or
    - (iii) other products that meet the designation above.
- 2.22 A liner **should** be installed in accordance with the manufacturer's instructions. Appropriate components **should** be selected to form the flue without cutting and to keep joints to a minimum. Bends and offsets **should** only be formed with matching factory-made components. Liners **should** be placed with the sockets or rebate ends uppermost to contain moisture and other condensates in the flue. Joints **should** be sealed with fire cement, refractory mortar or installed in accordance with their manufacturer's instructions.

Spaces between the lining and the surrounding masonry **should** not be filled with ordinary mortar. In the absence of the liner manufacturer's instructions, the space **should** be filled with one of the following weak insulating concrete mixes –

- (a) one part ordinary Portland cement to 20 parts suitable lightweight expanded clay aggregate, minimally wetted;
- (b) one part ordinary Portland cement to 6 parts Vermiculite; or
- (c) one part ordinary Portland cement to 10 parts Perlite.

### Construction of flueblock chimneys

- 2.23 A flueblock chimney **should** be constructed of factory-made components suitable for the intended application and installed in accordance with the manufacturer's instructions. The flueblocks **should** have a minimum performance that corresponds to the designation T400 N2 S D 3, as described in BS EN 1443:2003, such as clay flueblocks of Class FB1 N2 as described in BS EN 1806:2006.
- 2.24 Joints **should** be sealed in accordance with the flueblock manufacturer's instructions. Bends and offsets **should** only be formed with matching factory-made components.

### Thickness of masonry and flueblock chimneys

- 2.25 The thickness of the walls for a masonry chimney around the flue, excluding the thickness of any flue liner, **should** be in accordance with Diagram 2.4.

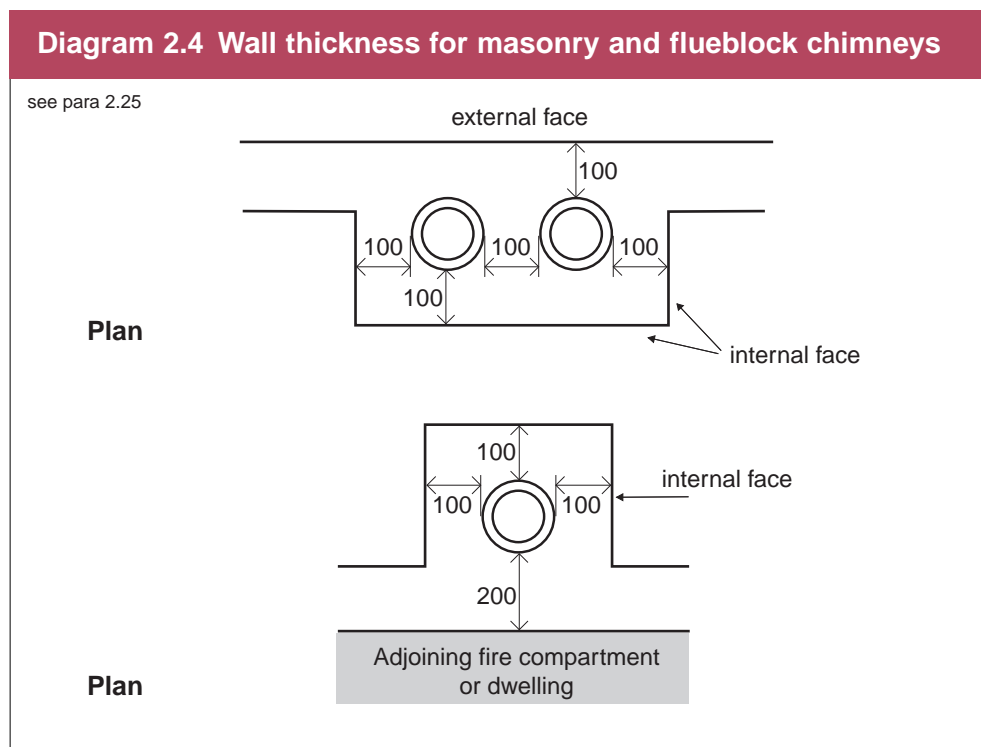

### Fluepipes

- 2.26 A fluepipe **should** be constructed from –
- (a) cast iron complying with BS 41:1973 (1998);

- (b) metal flue pipes appropriately designated in accordance with BS EN1856-2:2004 to suit the appliance and types of fuels to be burnt – refer to detailed guidance in Sections 3, 4 and 5;
  - (c) vitreous enamelled steel pipe complying with BS 6999:1989 (1996); or
  - (d) other fluepipes having the necessary performance designation for use with the intended appliance.
- 2.27 A fluepipe with spigot and socket joints **should** be fitted with the socket facing upwards to contain moisture and other condensates in the flue. Joints **should** be made gas-tight by the use of proprietary jointing accessories or, where appropriate, by packing joints with non-combustible rope or fire cement.
- 2.28 A plastic fluepipe **should be appropriately designated in accordance with BS EN 14471:2005 to suit the appliance, fuel and flue characteristics.**

### **Repair or re-use of existing flues**

- 2.29 Where it is proposed to bring an existing flue back into use, or an existing flue is to be used with a different type or rating of combustion appliance, it **should** be cleaned, visually inspected and if necessary altered to ensure that it is suitable for the proposed use.
- 2.30 A defective flue **should** be lined using the materials and components described in Sections 3, 4, and 5 dependent upon the type of combustion appliance proposed.
- 2.31 The use of an oversized flue can be unsafe so a flue **should** be lined to reduce the flue area to suit the intended combustion appliance.
- 2.32 If a chimney has been relined in the past using a metal lining system and the appliance is being replaced, the metal liner **should** also be replaced, unless it can be proven that it was recently installed and it can be seen to be in good condition.

### **Use of flexible metal flue liners for the relining of chimneys**

- 2.33 A chimney may be relined using a flexible metal flue liner, **appropriately designated in accordance with BS EN1856-2:2004 to suit the appliance, fuel and flue gas characteristics.** Flexible flue liners **should** only be used to reline a chimney and **should** not be used as the primary liner of a new chimney. They can be used to connect gas back boilers to chimneys where the appliance is located in a fireplace recess.

### **Factory-made metal chimneys**

- 2.34 A factory-made metal chimney **should** be –
- (a) a component system independently certified as complying with the relevant sections of BS EN 1856-1:2003 and installed in accordance with the relevant recommendations of **BS EN 15287-1:2007**; or
  - (b) a twin wall component system for an oil fired appliance and a single wall component system for gas complying with the recommendations of BS EN 1856 - 1: 2003 **and for gas appliances**, installed in accordance with the recommendations of BS 5440-1:2008, where the flue temperatures will not normally exceed 250 °C.

- 2.35 Where a factory-made metal chimney passes through a wall, sleeves **should** be provided to prevent damage to the flue or building through thermal expansion. To facilitate the checking of gas-tightness, joints between chimney sections **should** not be concealed within ceiling joist spaces or within the thickness of walls **unless proper access is provided**.
- 2.36 A factory-made metal chimney **should** be installed so that the appliance can be withdrawn without the need to dismantle the chimney.
- 2.37 A factory-made metal chimney **should** be kept a safe distance away from any combustible material. For a chimney **designated to BS EN 1856-1:2003** the following provisions are a reasonable method of achieving this –
- (a) locate the chimney not less than the distance “XX” from the combustible material, where “XX” is the dimension defined in **BS EN 1856-1:2003** as shown in Diagram 2.5; or
  - (b) where the chimney passes through a cupboard, storage space or roofspace, a suitable guard **should** be provided no closer to the outer wall of the chimney than “XX” **as given above** (see Diagram 2.5).

In no circumstances **should** the separation “XX” between the chimney and the combustible material, or suitable guard be less than 25 mm.

**Diagram 2.5 The separation of combustible material from a factory-made metal chimney passing through a cupboard, storage space or roofspace, meeting BS EN 1443: 2003**

see para 2.37

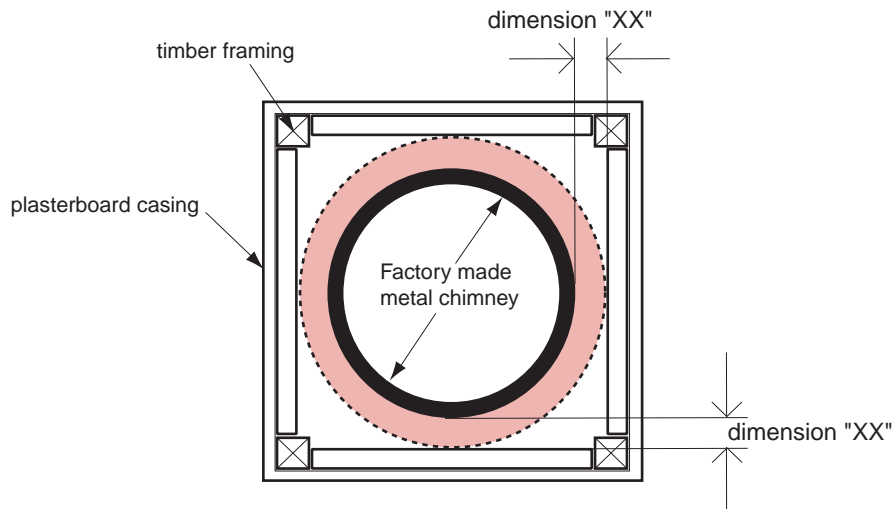

No combustible material in shaded zone. Width of shaded zone at least equal to manufacturer's declared minimum distance (XX mm) as defined by testing to BS EN 1443: 2003 or 25 mm, whichever is the greatest.

**Plan**

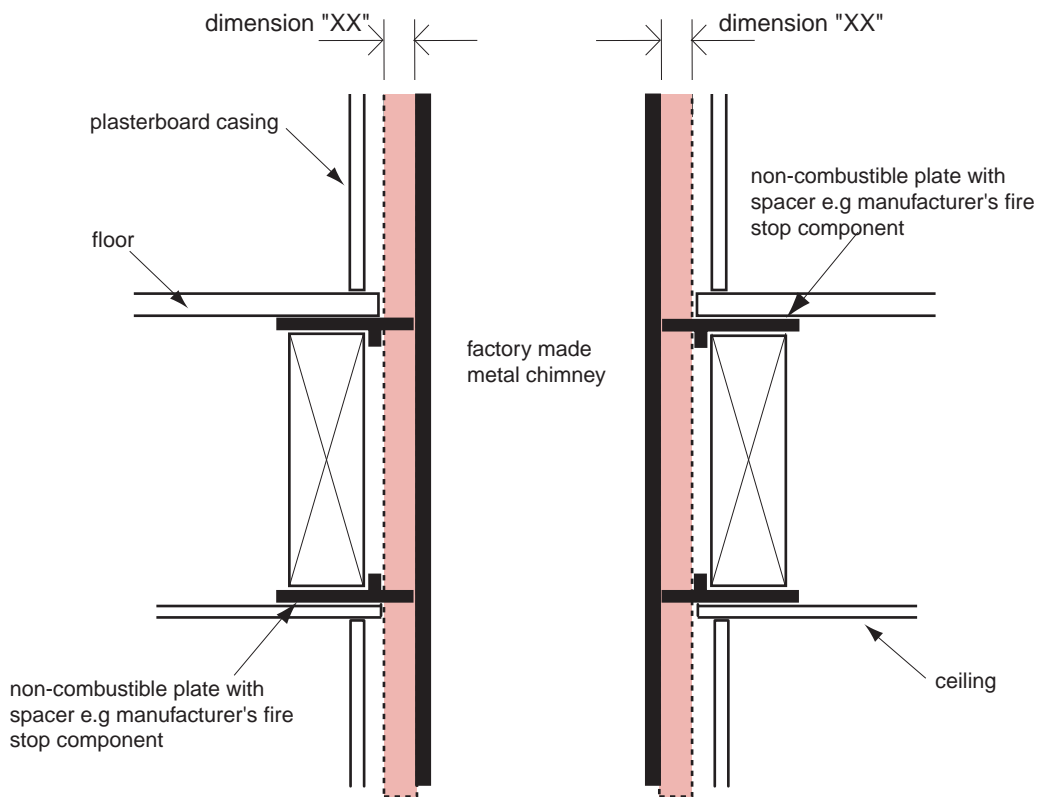

**Section**

- 2.38 Where a factory-made metal chimney penetrates a fire compartment wall or floor the casing of the chimney **should** be of non-combustible construction and have a period of fire resistance of not less than half that for the compartment wall or floor (see Part E, Fire safety).

### **Concealed flues**

- 2.39 Where a flue is routed within a void, appropriate means of access at strategic locations should be provided to allow the following aspects to be visually checked and confirmed –
- (a) the flue is continuous throughout its length;
  - (b) all joints appear correctly assembled and are appropriately sealed;
  - (c) the flue is adequately supported throughout its length; and
  - (d) any required gradient of fall back to the boiler (required to recover the condensate produced as part of the combustion process) and any other required drain points have been provided.

This is necessary when an appliance is first installed and will subsequently assist when the appliance is maintained.

The means of access for flues needs to be sufficiently sized and positioned to allow a visual inspection of the flue to be undertaken, particularly at any joints in the flue. It is not intended that the means of access should be sized to allow full physical access to the flue system.

Flues should not pass through another premises since access for inspection may not always be available to that premises and chimney system running through it. Flues may pass through communal areas including purpose-designed ducts where inspection access is provided.

Any 'means of access' should not impair any fire, thermal or acoustic requirements of the Building Regulations. Where necessary, inspection panels or hatches should be fitted with resilient seals and provide the similar standards of fire, thermal and acoustic isolation to the surrounding structure.

Access hatches should be at least 300 mm x 300 mm or larger where necessary to allow sufficient access to the void to look along the length of the flue.

Diagram 2.6 shows examples of access panels for a horizontal flue in a ceiling void.

Diagram 2.6 Example locations of access panels for concealed horizontal flues

see para 2.39

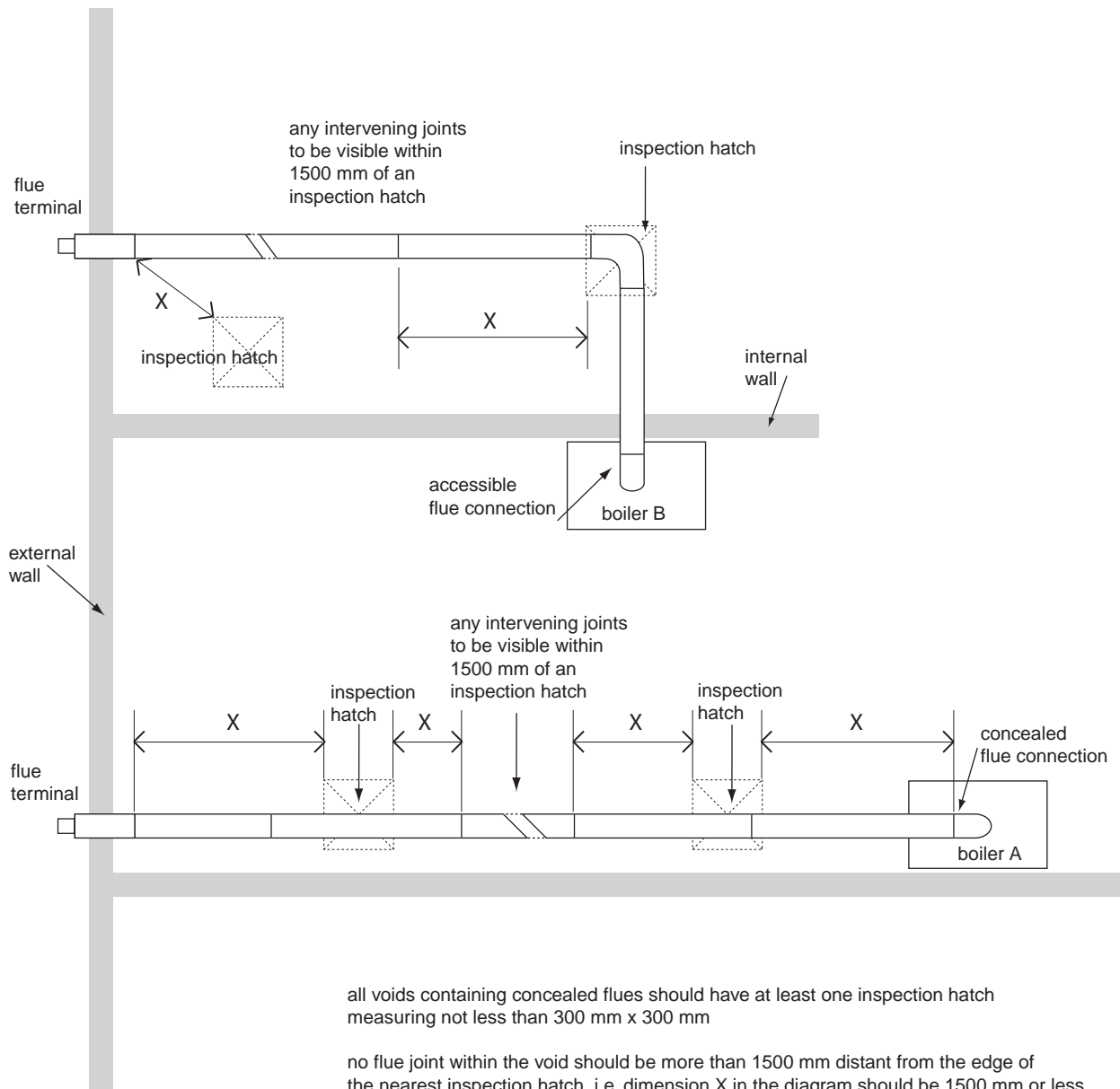

all voids containing concealed flues should have at least one inspection hatch measuring not less than 300 mm x 300 mm

no flue joint within the void should be more than 1500 mm distant from the edge of the nearest inspection hatch, i.e. dimension X in the diagram should be 1500 mm or less

where possible inspection hatches should be located at changes of direction - where this is not possible then bends should be viewable from both directions

Plan

## Configuration of natural draught flues serving open-flued appliances

- 2.40 A flue system **should** offer least resistance to the passage of the flue gas by minimising changes in direction or horizontal length. Where practicable the flue **should** be straight and vertical except for the connection to a combustion appliance with a rear outlet. The connecting horizontal section **should** not be greater than 150 mm in length and where bends are essential, they **should** be angled at not more than 45° to the vertical.
- 2.41 Provisions **should** be made to enable the flue to be swept and inspected. The number of changes of direction between the combustion appliance outlet and the flue outlet **should** be limited to not more than four 45° bends with not more than two of these being between an intended point of access for sweeping and either another point of access for sweeping or the flue outlet. 90° factory-made bends, elbows or tee pieces in fluepipes **should** be treated as being equal to two 45° bends (see Diagram 2.7).

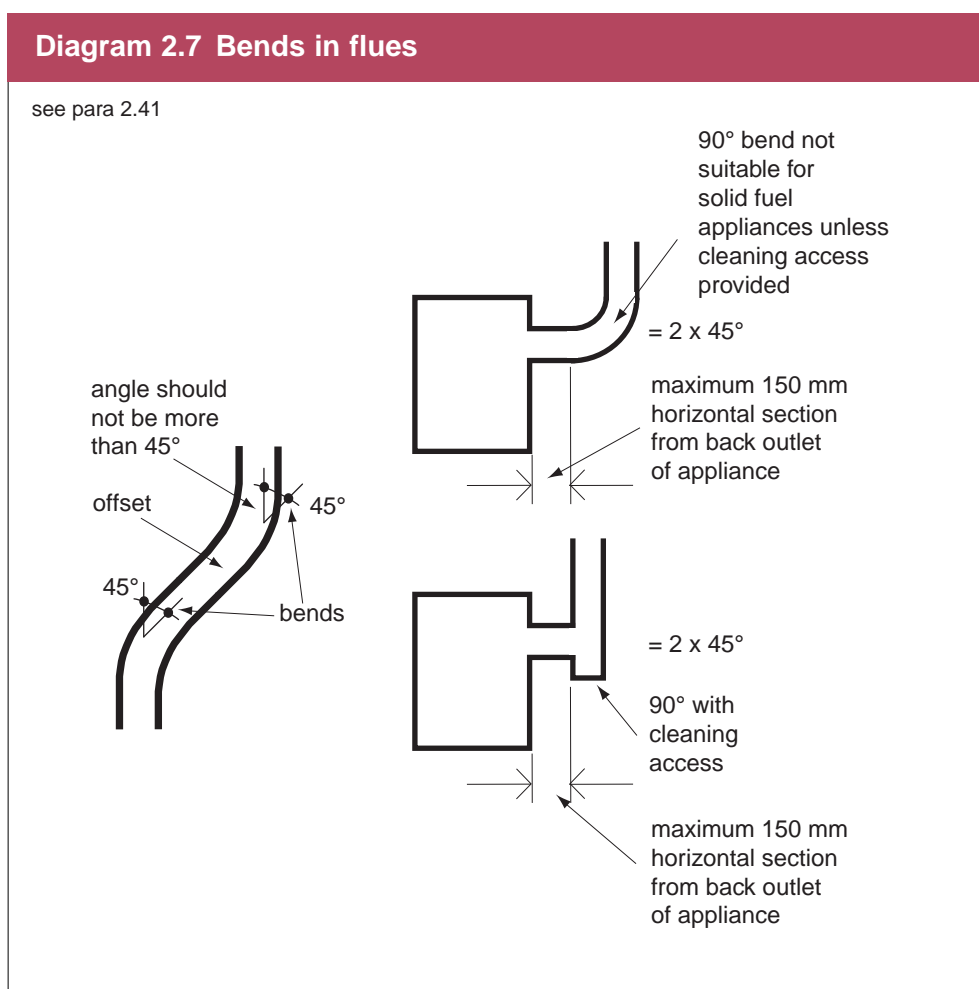

## Openings in flues for inspection and cleaning

- 2.42 A flue **should** not have an opening into more than one room or space except for the purposes of –
- inspection or cleaning; or
  - fitting an explosion door, draught break, draught stabiliser or draught diverter.

- 2.43 Openings for inspection and cleaning **should** be formed using purpose factory-made components that are compatible with the flue system. The access cover to the opening **should** have the same level of gas-tightness as the flue system and an equal level of thermal insulation.
- 2.44 Openings for cleaning the flue **should** allow easy passage of the sweeping brush and be non combustible except where fitted to a combustible fluepipe, such as a plastic fluepipe. It **should** be possible to sweep the whole flue after the appliance has been installed.

### **Dry lining around fireplace openings**

- 2.45 Where a decorative treatment, such as a fireplace surround, masonry cladding or dry lining, is provided around a fireplace opening, any gaps that could allow flue gas to escape from the fireplace opening into the void behind the decorative treatment **should** be sealed to prevent such leakage. The sealing material **should** be capable of remaining in place despite any relative movement between the decorative treatment and the fireplace recess.

### **Condition of combustion installations at completion**

- 2.46 A flue **should** be checked at completion to ensure that it is free from obstructions, satisfactorily gas-tight and constructed with materials and components of sizes that suit the intended application.

Where the building work includes the installation of a combustion appliance, all of the tests **should** include the fluepipe and the gas-tightness of the joint between the fluepipe and the combustion appliance outlet. A spillage test **should** be carried out with the appliance under fire.

### **Notice plates for hearths and flues**

- 2.47 To satisfy the requirements of Regulation L5 a durable notice **should** be provided to convey –
- (a) the location of the hearth, fireplace (or flue box) or the location of the beginning of the flue;
  - (b) the generic type(s) of combustion appliances that can be safely accommodated;
  - (c) the type and size of the flue (or its liner if it has been relined) and the manufacturer's name; and
  - (d) who installed the hearth, fireplace, flue or chimney and the date of installation.

Diagram 2.8 Notice plates for hearths and flues

see para 2.49

<b>Important Safety Information</b>	
This notice must not be removed or covered	
Property address:	20 Main Street, Anytown
Location of hearth & chimney:	Lounge
Suitable for:	Decorative fuel effect gas fire only
Chimney liner:	Double skin stainless steel flexible, 200 mm diameter
Suitable for condensing appliance:	No
Date installed:	dd/mm/yyyy
Installed by:	A N Other & Co.
Other information: (e.g. Product trade names, installation and maintenance advice, European flue product designations, warnings on performance limitations of imitation elements etc.)	Designation of stainless steel liner stated by manufacturer to be T450 N2 S D 3

- 2.48 Notice plates **should** be robust, indelibly marked and securely fixed in an unobtrusive but obvious position within the building such as –
- (a) next to the electricity consumer unit; or
  - (b) next to the chimney or hearth described.
- 2.49 For flue products whose performance characteristics have been assessed in accordance with a European Standard (EN) and which are supplied or marked with a designation as defined in Section 2, the installer **should** include this designation, under additional information, on the notice plate as shown in Diagram 2.8.

### Access to combustion appliances for maintenance

- 2.50 A permanent means of safe access **should** be provided to a combustion appliance for maintenance.

## Detection and warning of the release of carbon monoxide

### Carbon monoxide alarms

- 2.51 Where a new or replacement combustion appliance, not designed solely for cooking purposes, is installed in a dwelling, a carbon monoxide detector/alarm should be provided in the room where the appliance is located. However, if the combustion appliance is installed in a room or space not normally used e.g. a boiler room/cupboard, the detector/alarm should be located just outside the room or space. This will allow the alarm to be heard more easily.
- 2.52 Carbon monoxide alarms should comply with BS EN 50291:2001 and be powered by a battery designed to operate for the working life of the alarm. The alarm should incorporate a warning device to alert users when the working life of the alarm is due to pass. Mains-powered BS EN 50291 Type A carbon monoxide alarms with fixed wiring (not plug-in types) may be used as alternative applications provided they are fitted with a sensor failure warning device.
- 2.53 The carbon monoxide alarm should be located –
- (a) on the ceiling at least 300 mm from any wall or, if it is located on a wall, as high up as possible (above any doors and windows) but not within 150 mm of the ceiling; and
  - (b) between 1000 mm and 3000 mm horizontally from the appliance.

Further guidance on the installation of carbon monoxide alarms is available in BS EN 50292:2002 and from manufacturers' instructions.

## Section 3 Solid fuel burning appliances (including solid biofuel) with a rated heat output up to 50 kW

**This section sets out the additional provisions that should be met for a solid fuel burning combustion appliance over and above those given in Section 2.**

### **Air supply to appliances**

- 3.1 Any room or space containing a combustion appliance **should** have a permanent air vent opening of a size not less than that shown in Table 3.1. For an appliance designed to burn a range of different solid fuels the air supply **should** be designed to accommodate burning the fuel that produces the highest heating output.
- 3.2 Where the manufacturer's installation instructions require greater areas of permanently open air vents than those specified in Table 3.1, the manufacturer's advice **should** be followed.

**Table 3.1 Air supply to solid fuel burning appliances**

Type of appliance	Type and amount of ventilation (1)
Open appliance such as an open fire with no throat, e.g. a fire under a canopy as in Diagram 3.6	Permanently open air vent(s) with a total <b>equivalent area</b> of not less than 50% of the cross-sectional area of the flue
Open appliance, such as an open fire with a throat as in Diagram 3.5 and 3.12	Permanently open air vent(s) with a total <b>equivalent area</b> of not less than 50% of the throat opening area <sup>(2)</sup>
Other appliance, such as a stove, cooker or boiler, with a flue draught stabiliser.	Permanently open vents as below: If design air permeability >5.0 m <sup>3</sup> /(h.m <sup>2</sup> ) then - 300mm <sup>2</sup> /kW for first 5kW of appliance rated output; and 850mm <sup>2</sup> /kW for balance of appliance rated output. If design air permeability ≤5.0 m <sup>3</sup> /(h.m <sup>2</sup> ) then - 850mm <sup>2</sup> /kW of appliance rated output <sup>(3)</sup>
Other appliance, such as a stove, cooker or boiler, with no flue draught stabiliser.	Permanently open vents as below: If design air permeability >5.0m <sup>3</sup> /(h.m <sup>2</sup> ) then - 550mm <sup>2</sup> /kW of appliance rated output above 5kW If design air permeability ≤5.0m <sup>3</sup> /(h.m <sup>2</sup> ) then - 550mm <sup>2</sup> per kW of appliance rated output <sup>(3)</sup>
Notes:	
(1) Extract fans <b>should</b> not be installed in the same room or space as a solid fuel burning appliance, <b>see paragraph 2.17</b>	
(2) For simple open fires as depicted in Diagram 3.12 the air supply requirement can be met with room ventilation areas as follows -	
Nominal fireplace opening size	500 mm                      450 mm                      400 mm                      350 mm
Total <b>equivalent area</b> of permanently open air vents	20500 mm <sup>2</sup> 18500 mm <sup>2</sup> 16500 mm <sup>2</sup> 14500 mm <sup>2</sup>
(3) A dwelling constructed prior to 2008 will not normally have an air permeability of less than 5.0 m <sup>3</sup> /(h.m <sup>2</sup> ) at 50 Pa unless extensive measures have been taken to improve air tightness. See Appendix C. When it is not possible to determine if the air permeability of a dwelling is likely to be more than 5.0 m <sup>3</sup> /(h.m <sup>2</sup> ) then it should be assumed that the dwelling has an air permeability of 5.0 m <sup>3</sup> /(h.m <sup>2</sup> ) or less.	
(4) Example: an appliance with a flue draught stabiliser and a rated heat output of 7 kW would require a permanently open air vent with a <b>equivalent area</b> of - [5 x 300] + [2 x 850] = 3200 mm <sup>2</sup>	
5. Equivalent area is as measured according to the method in BS EN 13141-1:2004 or estimated according to paragraph 2.10. Divide the area given in mm <sup>2</sup> by 100 to find the corresponding area in cm <sup>2</sup>	

## Flues and chimneys

### Size of flues

- 3.3 A flue **should** be sized to suit the intended appliance to ensure an adequate discharge velocity of the flue gas that will prevent flow reversal problems but will not impose excessive flow resistance.
- 3.4 A fluepipe **should** have the same diameter or equivalent cross-sectional area as that of the appliance flue outlet and **should** not be smaller than the size recommended by the appliance manufacturer.

- 3.5 A flue **should** not be less than the size shown in Table 3.2 that is relevant to the particular appliance, and not less than the size of the appliance flue outlet or that recommended by the appliance manufacturer.
- 3.6 For a multifuel appliance, the flue **should** be sized to accommodate burning the fuel that generates the greatest rated heat output.
- 3.7 A fireplace with an opening greater than 500 mm x 550 mm or a fireplace exposed on two or more sides, such as a fireplace under a canopy or open on both sides of a central chimney breast, **should** have a flue with a cross-sectional area equal to 15% of the total face area of the fireplace opening(s).
- 3.8 The opening area of a fireplace **should** be calculated using the following formula –

$$\text{Face area (mm}^2\text{)} = \text{Total horizontal length of fireplace opening } \mathbf{L} \text{ (mm)} \times \text{Height of fireplace opening } \mathbf{H} \text{ (mm)}$$

Examples of L and H for large or unusual fireplace openings are shown in Diagram 3.1.

Diagram 3.1 Examples of large or unusual fireplace openings

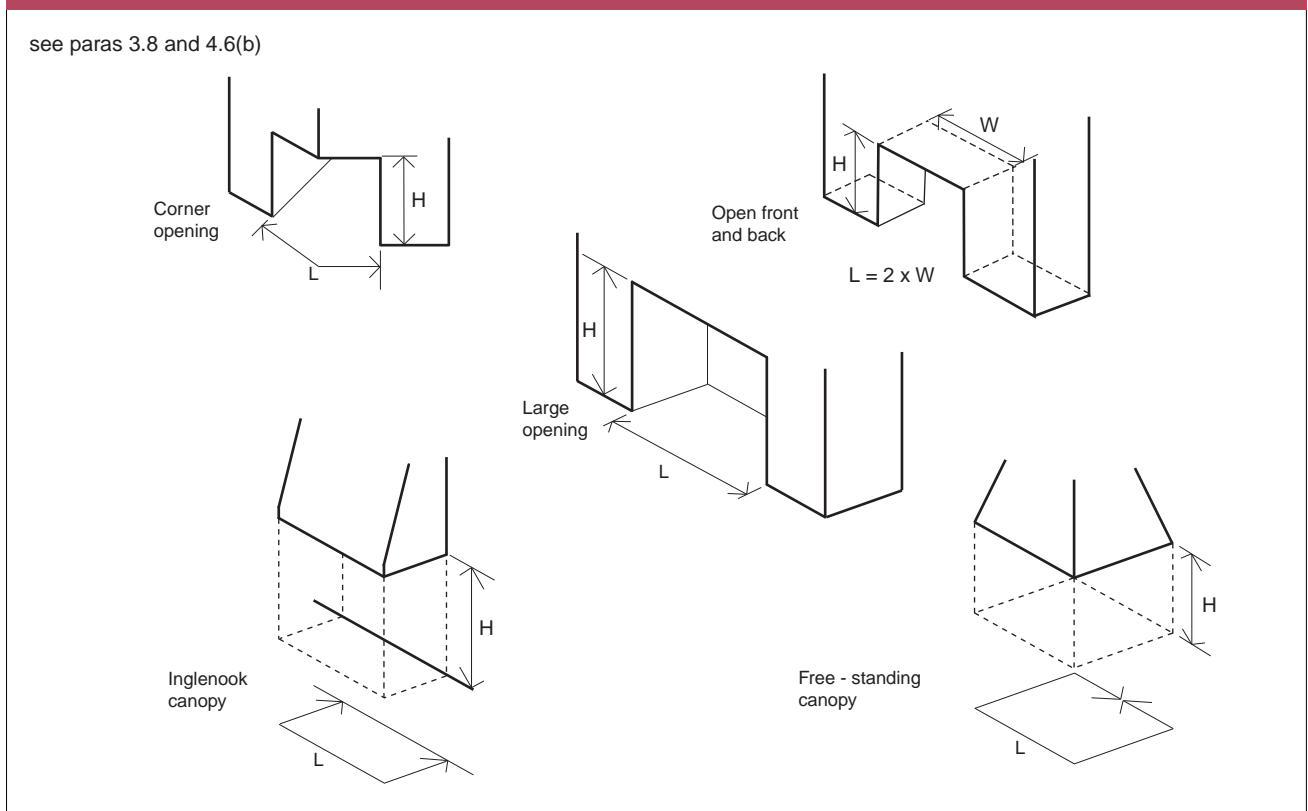

**Table 3.2 Sizes of flues for chimneys**

Installation <sup>(1)</sup>	Minimum flue size
Fireplace with an opening of up to 500 mm x 550 mm.	200 mm diameter or a rectangular/square section having the equivalent cross-sectional area and a minimum side dimension of 175 mm.
Fireplace with an opening greater than 500 mm x 550 mm or a fireplace exposed on two or more sides.	See paragraph 3.7. If a rectangular/square section flue is used the minimum side dimension <b>should</b> be not less than 200 mm.
Closed appliance with a rated heat output not greater than 20 kW which - <ol style="list-style-type: none"> <li data-bbox="161 551 794 584">burns smokeless or low volatiles fuel <sup>(2)</sup> ;</li> <li data-bbox="161 584 794 674">is an appliance which meets the requirements of the <b>Clean Air (Northern Ireland) Order</b> when burning an appropriate bituminous coal<sup>(3)</sup>; or</li> <li data-bbox="161 674 794 741">is an appliance which meets the requirements of the <b>Clean Air (Northern Ireland) Order</b> when burning wood<sup>(3)</sup>.</li> </ol>	125 mm diameter or rectangular/square section having the equivalent cross-sectional area and a minimum side dimension of 100 mm.
Pellet burner or pellet boiler which meets the requirements of the <b>Clean Air (Northern Ireland) Order</b> <sup>(3)</sup> .	125mm diameter This may be reduced to no less than 100mm when permitted by the appliance manufacturer and supported by calculation according to <b>BS EN 13384-1:2002</b> . This calculation can be applied to an individual installation or manufacturers can provide precalculated designs.
Other closed appliances with a rated heat output not greater than 30 kW burning any fuel.	150 mm diameter or rectangular/square section having the equivalent cross-sectional area and a minimum side dimension of 125 mm.
Closed appliances with a rated heat output greater than 30 kW but not exceeding 50 kW burning any fuel.	175 mm diameter or rectangular/square section having the equivalent cross-sectional area and a minimum side dimension of 150 mm.
Notes: (1) Closed appliance includes cookers, stoves, room heaters and boilers. (2) Fuels such as bituminous coal, untreated wood or compressed paper are not smokeless or low volatiles fuel. (3) These appliances are known as 'exempted fireplaces' 4. Should an offset be necessary in a flue, each flue size dimension should be increased by 25 mm (i.e. diameter or side).	

### Height of flues

- 3.9 A flue **should** be high enough to ensure a sufficient draught to clear the products of combustion. The height necessary for this will depend upon the type of the appliance, the height of the building, the type of flue and the number of bends in it, and a careful assessment of local wind patterns. A flue **should** be satisfactory if –
- it is at least 4.5 m in height and the provisions of paragraphs 3.11 to 3.13 are adopted; or
  - the calculation procedure within **BS EN 13384-1:2002** is used as the basis for deciding whether a flue design will provide sufficient draught.
- 3.10 The height of a flue serving an open fire is measured vertically from the highest point at which air can enter the fireplace to the level at which the flue discharges into the outside air. The highest point of air entry into the fireplace **should** be the top of the fireplace opening or, for a fire under a canopy, the bottom of the canopy. **The height of a flue serving a closed appliance is measured vertically from the appliance outlet.**

## Outlets from flues

- 3.11 The outlet from a flue **should** be above the roof of the building in a position where the products of combustion can discharge freely and will not present a fire hazard, whatever the wind conditions.
- 3.12 The flue outlet position, in common circumstances, **should** be in accordance with Table 3.3. However, the flue outlet position and/or separations shown in Table 3.3 may have to be increased, in particular cases, where the wind exposure, surrounding tall buildings, high trees or high ground have an adverse effect on the flue draught.

**Table 3.3 Flue outlet positions for solid fuel appliances**

Item	Point where flue passes through weather surface <sup>(1)(2)</sup>	Clearance to flue outlet
1	At or within 600 mm of the ridge.	Not less than 600 mm above the ridge.
2	Elsewhere on a roof, whether pitched or flat.	Not less than 2300 mm horizontally from the nearest point on the weather surface; and (a) not less than 1000 mm above the highest point of intersection of the flue/chimney and the weather surface; or (b) not less than as high as the ridge.
3	Below (on a pitched roof) or within 2300 mm horizontally to an openable rooflight, dormer window or other opening <sup>(3)</sup> .	Not less than 1000 mm above the top of the opening.
4	Within 2300 mm of an adjoining building, whether of not beyond the boundary <sup>(3)</sup> .	Not less than 600 mm above the adjacent building.
<p>Notes:</p> <p>(1) The weather surface is the building external surface, such as its roof, tiles or external walls.</p> <p>(2) A flat roof has a pitch less than 10°.</p> <p>(3) The clearances given for items 1 and 2, as appropriate, will also apply.</p> <p>4. A vertical flue fixed to an outside wall should be treated as equivalent to an inside flue emerging at the nearest edge of the roof.</p>		

- 3.13 Where a flue discharges onto, or in close proximity to, a roof with a surface that is readily ignitable, such as thatch or shingles, the clearances to the flue outlet **should** be increased to that shown in Diagram 3.2.

It should be noted that thatched roofs can sometimes be vulnerable to spontaneous combustion caused by heat transferred from flues building up in thick layers of thatch in contact with the chimney. To reduce the risk it is recommended that rigid twin-walled insulated metal flue liners be used within a ventilated (top and bottom) masonry chimney void provided they are adequately supported and not in direct contact with the masonry. Non-metallic chimneys and cast in-situ flue liners can also be used provided the heat transfer to the thatch is assessed in relation to the depth of thatch and risk of spontaneous combustion.

**Diagram 3.2 Flue outlet positions for solid fuel appliances - clearances to easily ignited roof**

see para 3.13

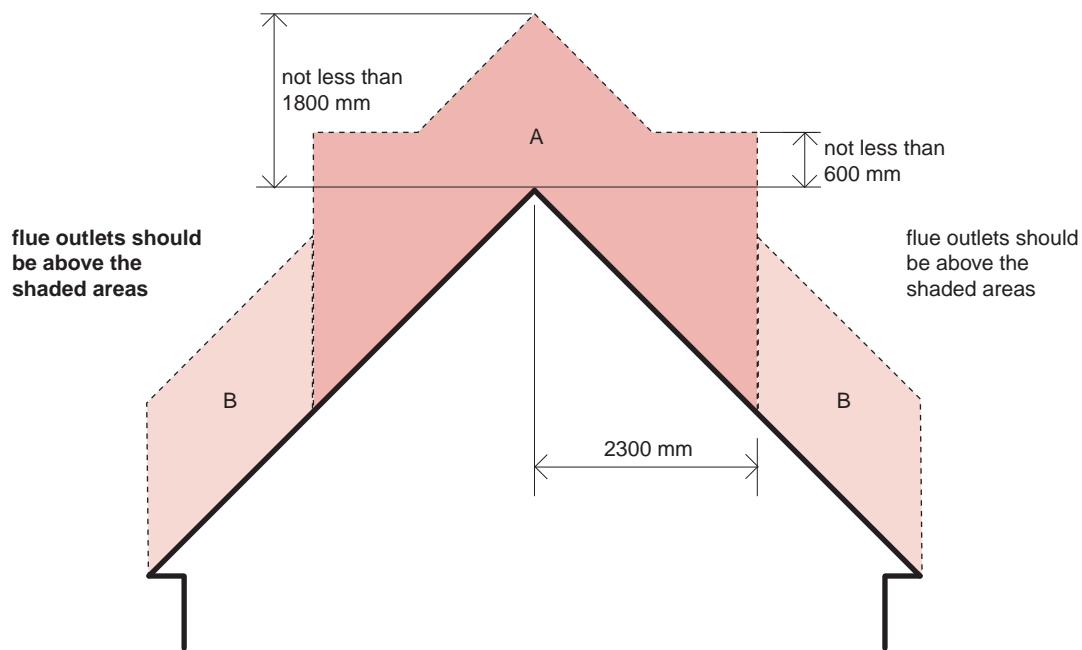

Area	Location of flue outlet
A	not less than 1800 mm vertically above the weather surface and not less than 600 mm above the ridge.
B	not less than 1800 mm vertically above the weather surface and not less than 2300 mm horizontally from the weather surface

**This diagram must be read in conjunction with Table 3.3**

### Location and shielding of fluepipes

- 3.14 A fluepipe **should** only be used to connect an appliance to its flue. It **should** not pass through any roof space, partition, internal wall or floor, except to pass directly into a flue through either a wall of the chimney or a floor supporting the chimney. A fluepipe **should** also be guarded if it could be at risk of damage or if the burn hazard it presents to people is not immediately apparent.
- 3.15 A fluepipe **should** be located so that it cannot ignite any combustible material. To ensure this –
- follow the guidance in paragraph 2.37 where the connecting fluepipe is a factory-made metal chimney whose performance is at least equal to designation T400 N2 D3 G according to BS EN 1856-1:2003 or BS EN 1856-2:2004, and installed to BS EN 15287-1; or
  - separation by shielding in accordance with Diagram 3.3.

### Diagram 3.3 Protecting combustible material from uninsulated fluepipes for solid fuel appliances

see para 3.15

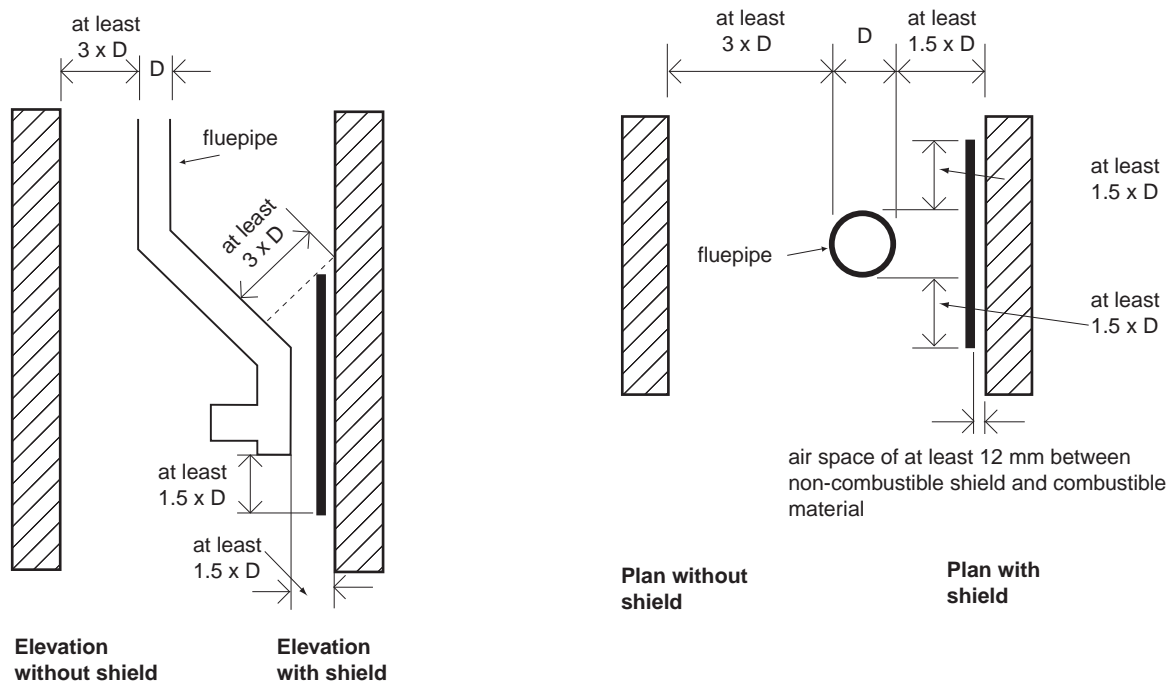

shields shall either:

- extend beyond the fluepipe by at least  $1.5 \times D$ ; or
- make any path between fluepipes and combustible material at least  $3 \times D$  long



indicates combustible material

### Debris collection space

- 3.16 Where a flue cannot be cleaned through the appliance, a debris collecting space that is accessible for emptying and suitably sized opening(s) for cleaning **should** be provided at appropriate locations in the flue.

### Masonry and flueblock chimneys

- 3.17 Masonry chimneys should be built in accordance with paragraphs 2.21 and 2.22. Flueblock chimneys should be built in accordance with paragraphs 2.23 and 2.24. The minimum chimney thickness and distance to combustibles (xx mm) should be no less than the manufacturer's product declaration (Gxx) based on testing to BS EN 1858:2008 (concrete flue blocks) or BS EN 1806:2006 (clay/ceramic flueblocks). Other masonry chimney products should exceed the minimum thickness indicated in Diagram 2.4.

### Separation of combustible material from fireplaces and flues

- 3.18 Combustible material **should** not be located where the heat dissipating through the walls of a fireplace or flue could ignite it. The minimum separation distances for combustible material **should** be –
- (a) 200 mm from the inside surface of a flue or fireplace recess;
  - (b) at least xx mm from a flue product with designated separation distance (Gxx); or
  - (c) 40 mm from the outer surface of a masonry chimney or fireplace recess unless it is a floorboard, skirting board, dado rail, picture rail, mantel shelf or architrave. Metal fixings in contact with combustible materials **should** be not less than 50 mm from the inside surface of a flue.

(See Diagram 3.4.)

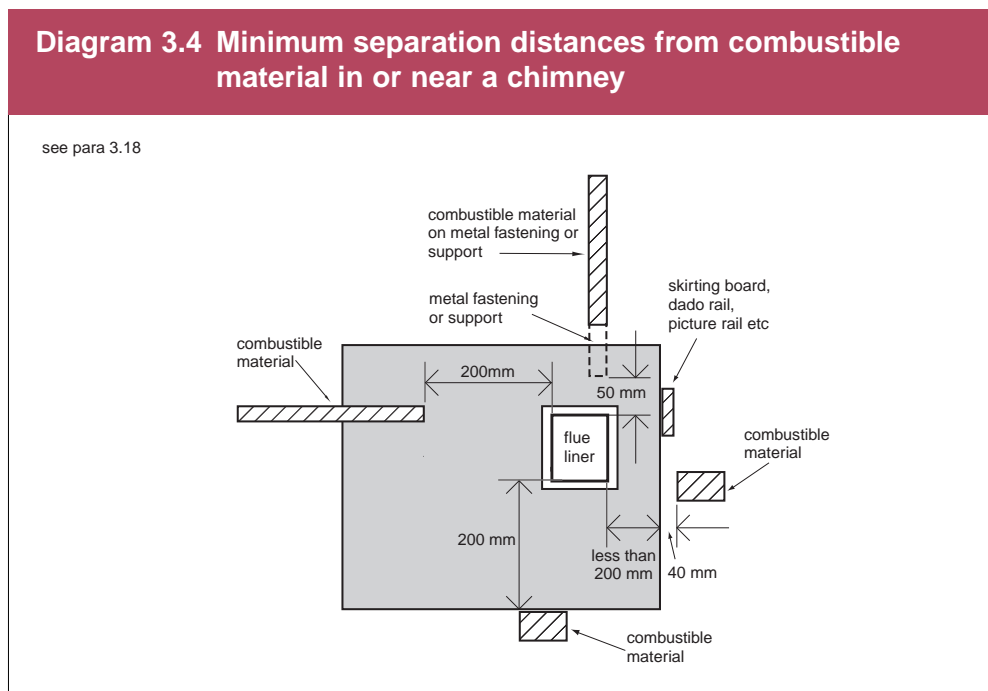

## Factory-made metal chimneys

- 3.19 Guidance on factory-made metal chimneys is given in paragraphs 2.34(a) and 2.35 to 2.38. Table 3.4 gives minimum performance designations for chimney and fluepipe components for use with new solid fuel fired appliances.

Table 3.4 Minimum performance designations for chimney and fluepipe components for use with new solid fuel fired appliances		
Appliance type	Minimum designation	Fuel type
All solid fuel appliances	Masonry or flueblock flue with liner to T400 N2 D3 Gxx	Coal, smokeless fuel, peat, wood and other biomass
	Clay flue blocks FB1N2	
	Clay/ceramic liners B1N2	
	Concrete liners B2	
	factory-made metal chimneys to T400 N2 D3 Gxx	
See paragraph 2.21 to 2.24 and 2.34(a)		

## Lining or relining flues in chimneys

- 3.20 The lining of a flue **should** correspond to the designation T400 N2 D3 G, as described in BS EN 1443: 2003.

## Formation of gathers

- 3.21 To minimise resistance to the proper working of a flue, a tapered gather **should** be provided in the fireplace for an open fire. This **should** be formed by –
- using prefabricated gather components built into a fireplace recess as shown in Diagram 3.5(a);
  - the corbelled masonry as shown in Diagram 3.5(b); or
  - using a suitable canopy, as shown in Diagram 3.6.

Diagram 3.5 Construction of gathers

see para 1.2 throat  
see para 3.21 (a) and (b)

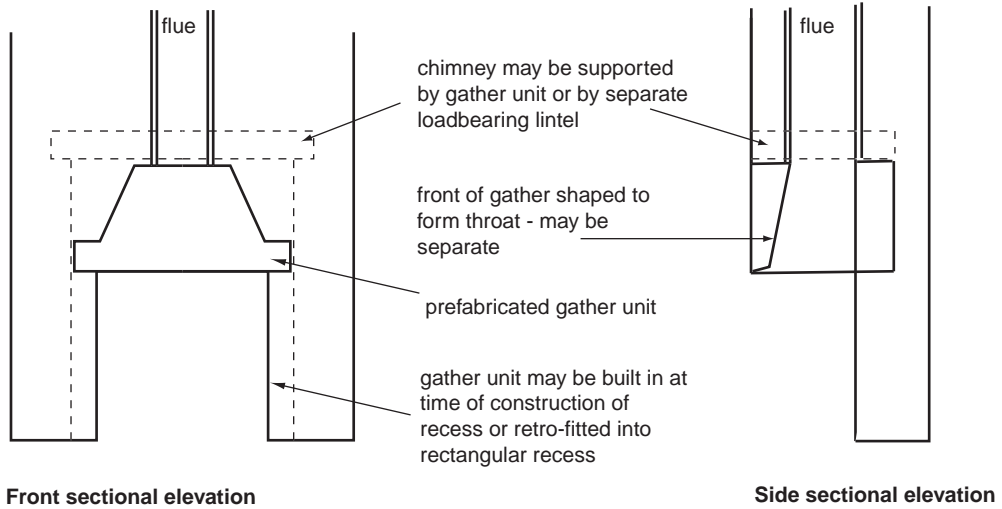

(a)

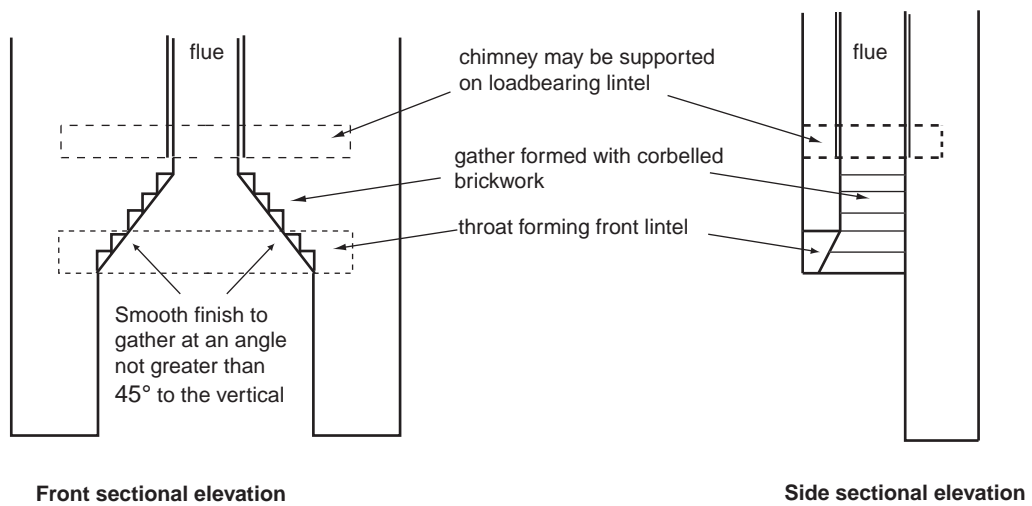

(b)

Diagram 3.6 Canopy for an open solid fuel fire

see para 3.21 (c)

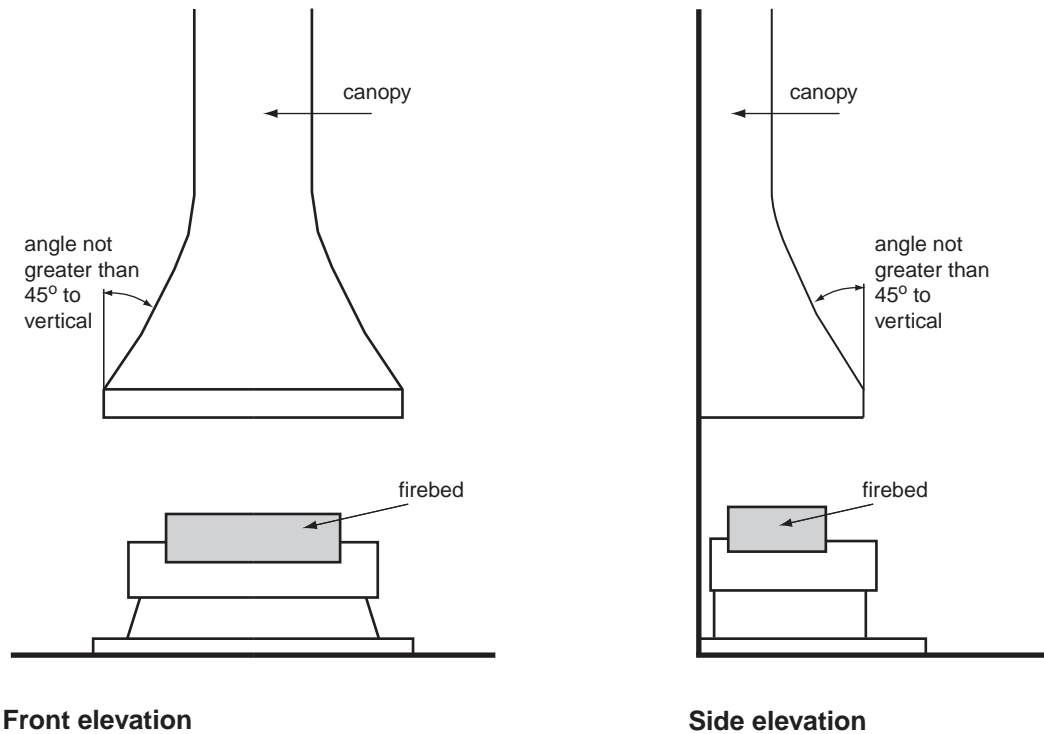

## Hearths

- 3.22 A hearth **should** be constructed of suitably robust materials and to appropriate dimensions so that, in normal use, it prevents the combustion appliance setting fire to the building fabric and furnishings.

If the chimney is not independently supported, the hearth **should** be able to accommodate the weight of the combustion appliance and its chimney.

- 3.23 Where an appliance is not to be located in an appliance recess and it has been independently certified that it cannot cause the temperature of the hearth to exceed 100 °C, it **should** stand wholly on a hearth made of non-combustible board, sheet material or tiles not less than 12 mm thick (see Diagram 3.10(a)).

All other appliances **should** be placed on a constructional hearth in accordance with paragraphs 3.24 to 3.29 (see Diagram 3.10(b) and (c)).

### Constructional hearths

- 3.24 A constructional hearth **should** –
- have plan dimensions not less than those shown in Diagram 3.7; and
  - be made of solid, non-combustible material, such as concrete or masonry, not less than 125 mm thick, including the thickness of any non-combustible floor and/or decorative surface.

### Diagram 3.7 Constructional hearth suitable for a solid fuel appliance (including open fires)

see paras 3.24, 4.33 and 5.27(a)

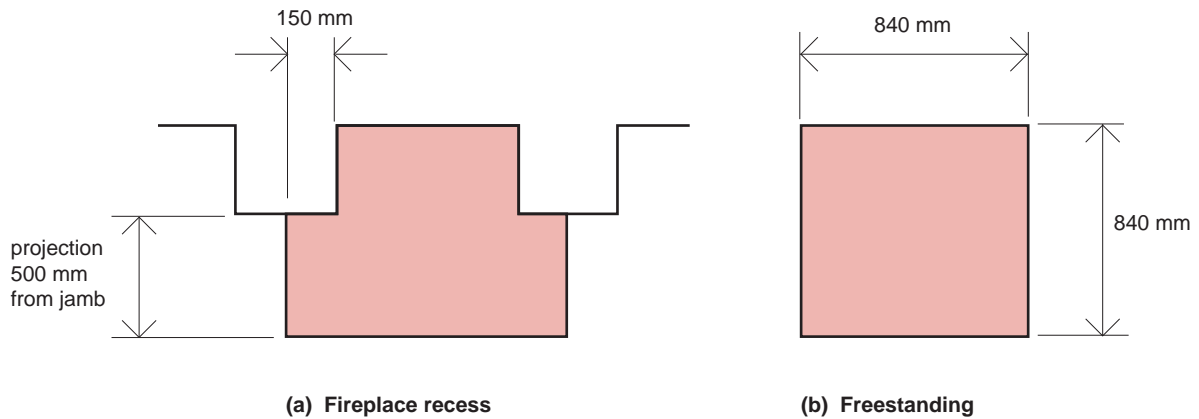

Plan

- 3.25 Combustible material **should** not be placed beneath a constructional hearth unless –
- there is an air-space of not less than 50 mm between the underside of the hearth and the combustible material; or
  - the combustible material is not less than 250 mm below the top of the hearth (see Diagram 3.8).

### Diagram 3.8 Minimum separation distances for combustible materials below a constructional hearth

see para 3.25  
see para 5.28

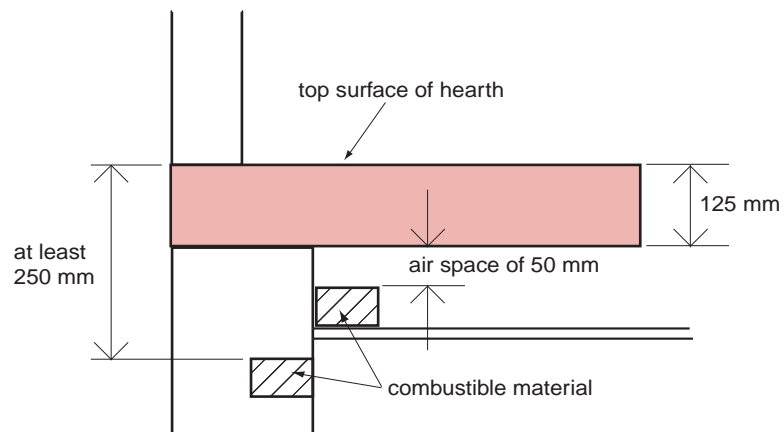

Section through hearth

- 3.26 An appliance **should** be located on a hearth so that it is surrounded by a surface free of combustible material as shown in Diagram 3.9. This surface may be part of the surface of the constructional hearth or it may be the surface of a superimposed hearth laid wholly or partly upon a constructional hearth. The edges of this surface **should** be marked with a change in level to provide a warning to the building occupants and to discourage combustible floor finishes such as carpet from being laid too close to the appliance.

**Diagram 3.9 Non-combustible hearth surface surrounding a solid fuel appliance**

see para 3.26  
see dia 3.7

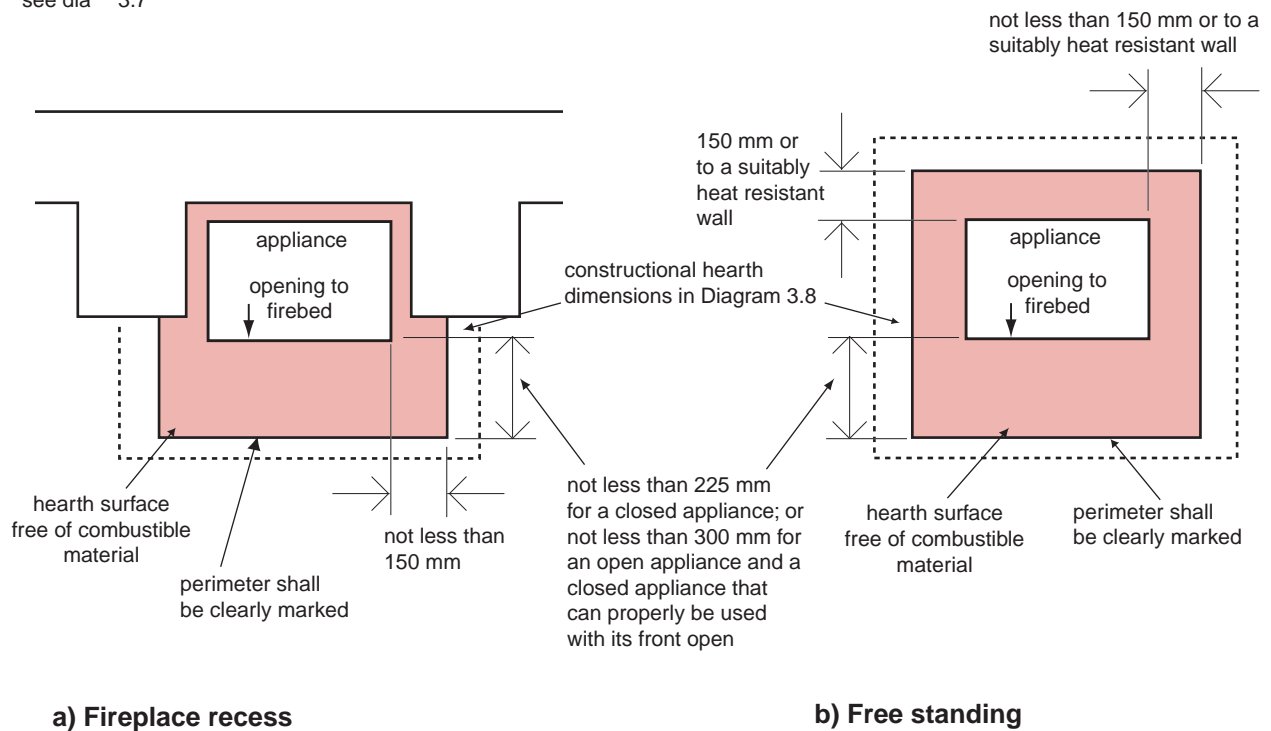

- 3.27 The dimensions shown in Diagram 3.9 may be reduced to manufacturer's recommendations for appliances with surface temperatures not exceeding 85 °C when in normal operation and where there is no risk of spillage of fuel or ash.
- 3.28 Combustible material placed on or beside a constructional hearth **should** not extend under a superimposed hearth by more than 25 mm or closer than 150 mm, measured horizontally, to the appliance (see Diagram 3.10(c)).
- 3.29 Hearths **should** be installed as shown in Diagram 3.10(b) and (c).

**Diagram 3.10 Typical hearth installations**

see paras 3.23 and 3.29  
see Diagrams 3.7 & 3.9

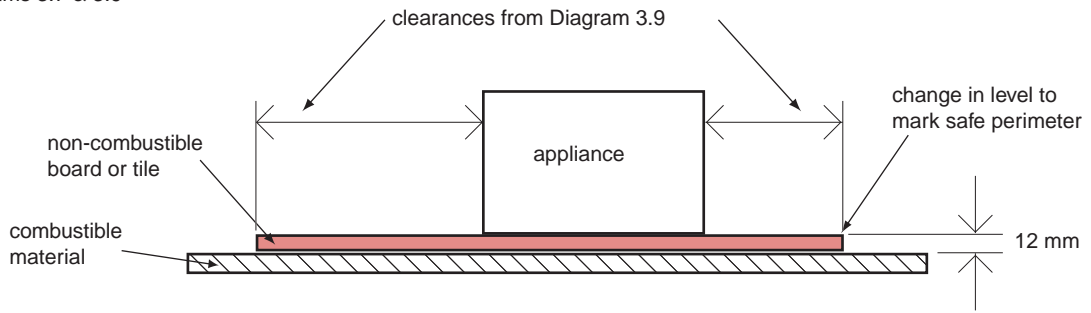

**(a) Appliance that cannot cause hearth temperature to exceed 100°C**

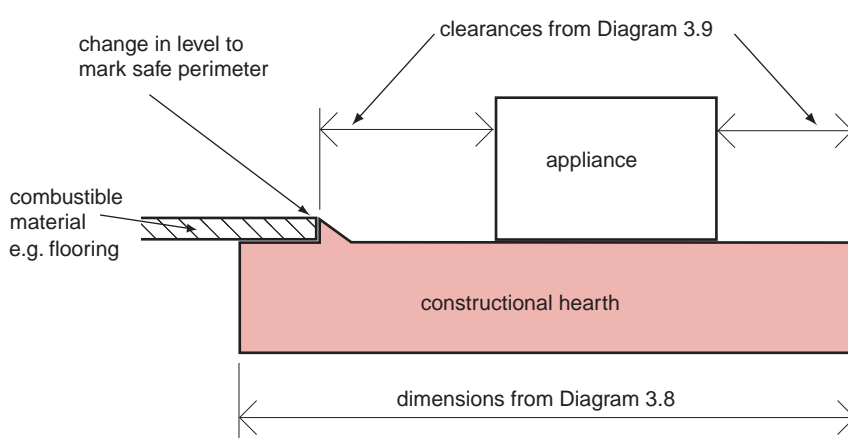

**(b) Appliance standing directly on a constructional hearth**

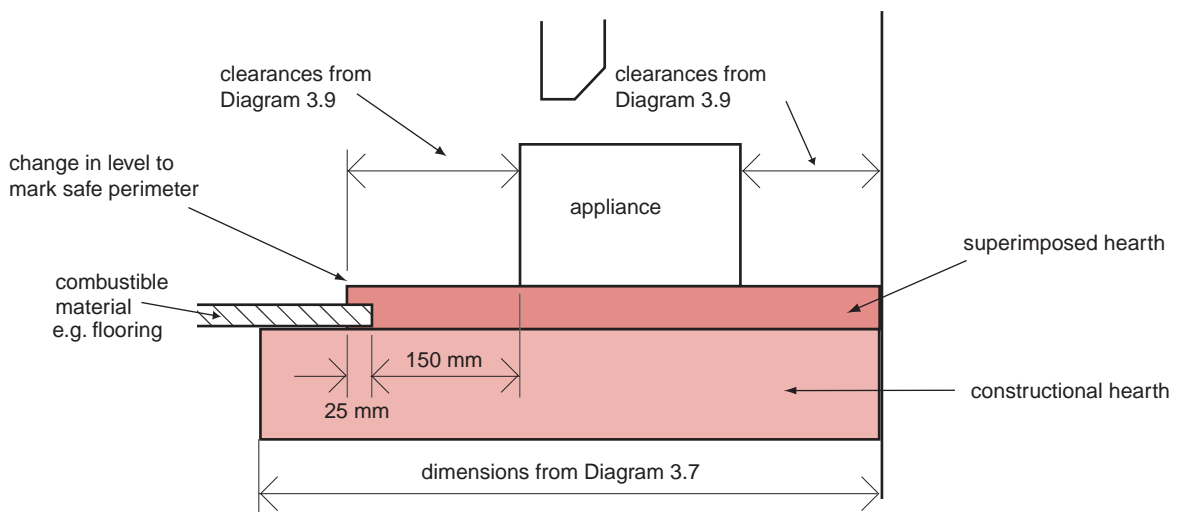

**(c) Appliance in a fireplace recess with a superimposed hearth**

## Fireplace recesses and prefabricated appliance chambers

- 3.30 Fireplaces **should** be designed and constructed so that they adequately protect the building fabric from catching fire. They **should** be built utilising –
- a fireplace recess of masonry or concrete as shown in Diagram 3.11; or
  - a prefabricated factory-made appliance chamber using components that are made of insulating concrete having a density of greater than  $1200 \text{ kg/m}^3$  but less than  $1700 \text{ kg/m}^3$  and a minimum thickness as shown in Table 3.5. Components **should** be supplied as a set for assembly and jointing in accordance with the manufacturer's instructions.

**Table 3.5 Minimum thickness of components for prefabricated appliance chambers**

Component	Minimum thickness (mm)
Base	50
Side section, forming wall on either side of chamber	75
Back section, forming rear chamber	100
Top slab, lintel or gather, forming top of chamber	100

**Diagram 3.11 Fireplace recesses**

see para 3.30 (a)

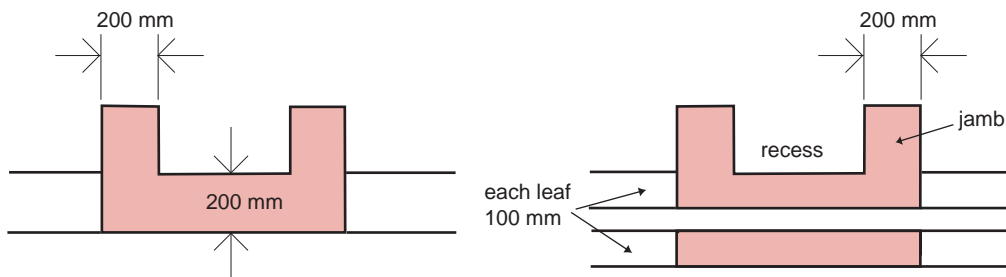

(a) Solid wall

(b) Cavity wall

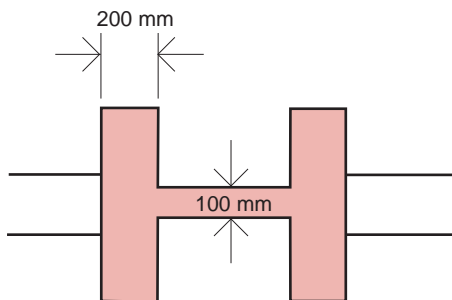

(c) Back to back (within the same dwelling)

**Plans**

### Fireplace lining components

- 3.31 A fireplace recess **should** be protected from the heat of the combustion appliance by suitable fireplace lining components as shown in Diagram 3.12, or by lining the recess with suitable firebricks.

**Diagram 3.12** Open fireplaces: throat and fireplace components

see para 3.31

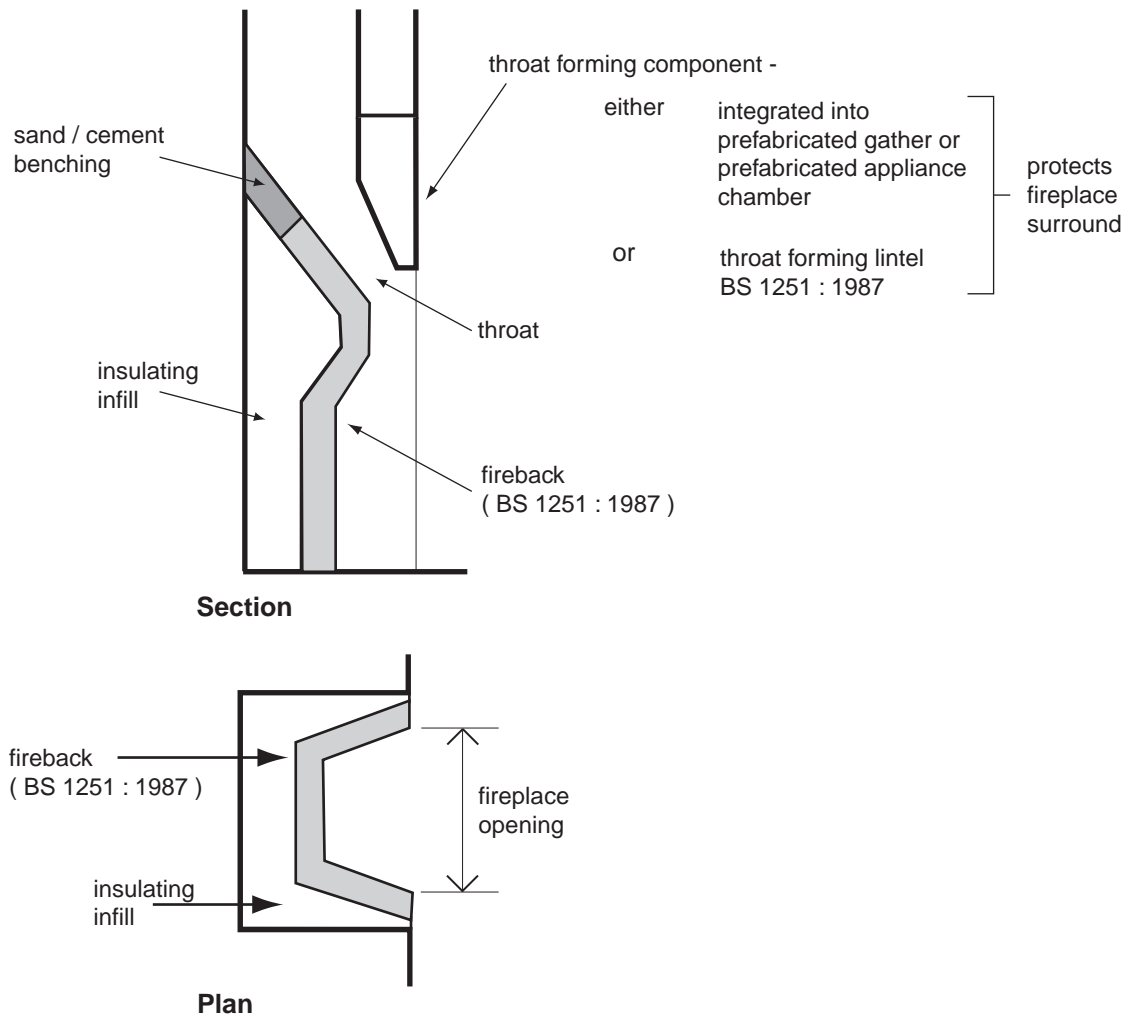

### Walls adjacent to hearths

- 3.32 Walls that are not part of a fireplace recess or a prefabricated appliance chamber, but are adjacent to a hearth or appliance, **should** protect the building from catching fire. They **should** be constructed in accordance with the provisions given in Diagram 3.13 and Table 3.6. **Clearances shown in Diagram 3.13 may be reduced to manufacturer's recommendations for appliances with surface temperatures not exceeding 85 °C when in normal operation.**

**Diagram 3.13 Walls adjacent to hearths**

see para 3.32  
see Diagram 3.9  
see Table 3.6

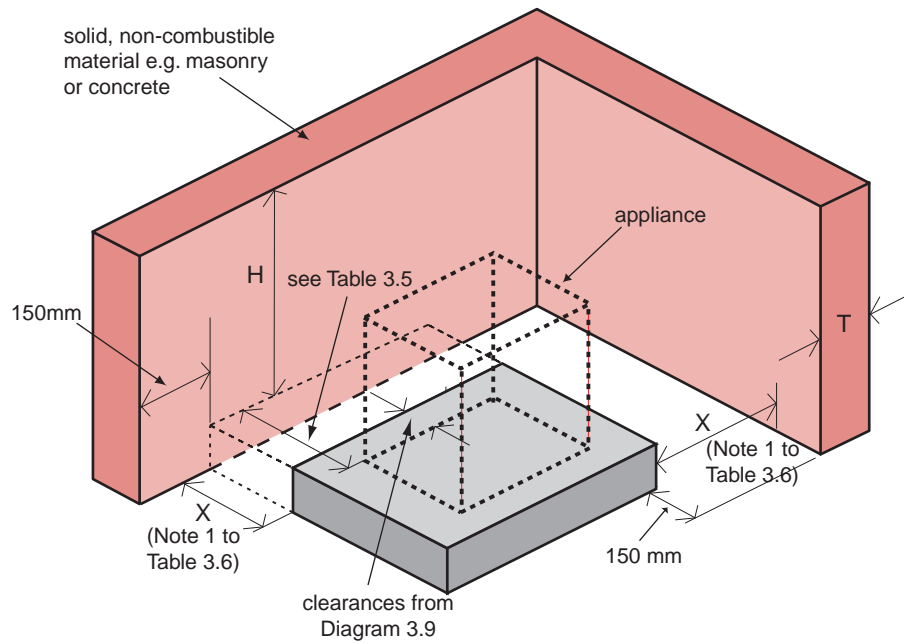

**Table 3.6 Dimensions of solid non-combustible walls adjacent to hearths**

Location of hearth or appliance	Solid non-combustible material	
	Thickness (T)	Height (H)
where the hearth abuts a wall and the appliance is not more than 50 mm from the wall	200 mm	not less than 300 mm above the appliance and not less than 1200 mm above the hearth
where the hearth abuts a wall and the appliance is more than 50 mm but not more than 300 mm from the wall	75 mm	not less than 300 mm above the appliance and not less than 1200 mm above the hearth
where the hearth does not abut a wall and is not more than 150 mm from the wall (see note below)	75 mm	not less than 1200 mm above the hearth

Note:

1. There is no requirement for protection of the wall where X in Diagram 3.13 is more than 150 mm.

## Section 4 Gas burning appliances with a rated heat input up to 70 kW (net)

This section sets out the additional provisions that **should** be met for gas burning appliances over and above those given in Section 2.

### Gas burning appliances

#### Gas fires (other than flueless gas fires)

- 4.1 Diagram 4.1 shows the three main types of gas-fired combustion appliances in this category, **the building provisions for accommodating them safely differ for each type.**
- 4.2 A gas fire **should** be installed in a fireplace that has –
- (a) a flue designed specifically for a gas appliance; or
  - (b) a flue designed to serve a solid fuel appliance, provided it can be shown to be safe.

The Gas Appliances (Safety) Regulations 1995 (*Northern Ireland Statutory Instrument 1995 No. 1629*) require that particular combinations of appliance, flue box (where required) and flue must be selected from those stated in the manufacturer's instructions as having been shown to be safe by a Notified Body.

#### Flueless instantaneous water heaters

- 4.3 A flueless instantaneous water heater **should** not be installed in a room or space having a volume of less than 5 m<sup>3</sup>.

#### Appliances fitted in bedrooms, bathrooms and shower rooms

- 4.4 An open-flued gas-fired appliance **should** not be installed in a bedroom, bathroom or shower room, as there is an increased risk of carbon monoxide poisoning. If a combustion appliance must be installed in such a room then a room-sealed appliance **should** be provided.

## Diagram 4.1 Types of gas fire

see para 4.1 &amp; 4.32

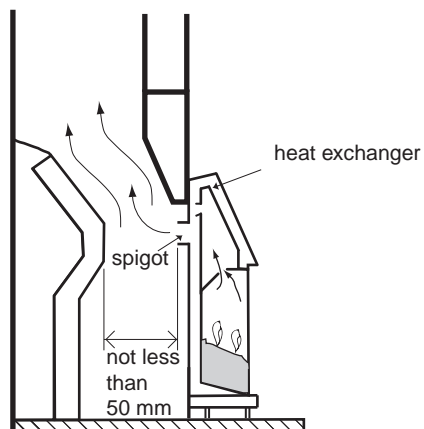

(a) Radiant convector gas fire

**Radiant convector gas fires, convector heaters and fire / back boilers, as described in BS 5871: Part 1: 2005**

These stand in front of a closure plate which is fitted to the fireplace opening of a fireplace recess or suitable fluebox. The appliance covers the full height of the fireplace opening so that air only enters through purpose designed openings and the flue gases only discharge through the flue spigot.

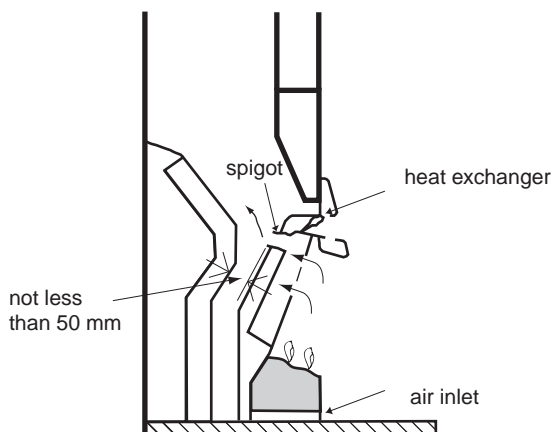

(b) Inset Live Fuel Effect (ILFE) fire

**Inset Live Fuel Effect (ILFE) fires, as described in BS 5871: Part 2: 2005**

These stand fully or partially within a fireplace recess or suitable fluebox and give the impression of an open fire. The appliance covers the full height of the fireplace opening so that air only enters through purpose designed openings and the flue gases only discharge through the spigot.

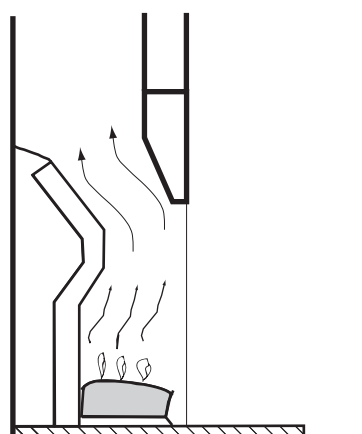

(c) Decorative Fuel Effect (DFE) fire

**Decorative Fuel Effect (DFE) fires, as described in BS 5871: Part 3: 2005**

These are gas-fired imitations which can be substituted for the solid fuel appliances in open fires. Where suitable, they can also be used in flueboxes designed for gas appliances only.

Common designs include beds of artificial coals shaped to fit into a fireplace recess or baskets of artificial logs for use in larger fireplaces or under canopies.

Note: For illustration purposes, this diagram shows gas fires installed at or within a fireplace recess formed by fireplace components within a builder's opening. The actual setting for an appliance depends upon its type and manufacturer's installation instructions.

## Air supply and ventilation

### Air supply for flued Decorative Fuel Effect (DFE) fires

- 4.5 A permanently open air vent will not be necessary for a DFE fire provided -
- (a) the dwelling in which it is to be installed has an air permeability greater than  $5.0 \text{ m}^3/\text{hr}/\text{m}^2$  (see Appendix C);
  - (b) the appliance has a rated heat input not greater than 7 kW (net); and
  - (c) there is a flue gas clearance rate (without spilling) not greater than  $70 \text{ m}^3/\text{hour}$ .
- 4.6 Where the provisions of paragraph 4.5 do not apply, any room or space intended to contain any other DFE fire should have a permanently open air vent as follows –
- (a) for a DFE fire in a fireplace recess with a throat, the air vent equivalent area should not be less than  $10000 \text{ mm}^2$ ; or
  - (b) for a DFE fire in a fireplace with no throat, such as a fire under a canopy, the air vent free area should be sized in accordance with the provisions in Section 3, Table 3.1, as if the room were intended to contain a solid fuel fire.

### Air supply for flued appliances other than Decorative Fuel Effect (DFE) Fires

- 4.7 This type of combustion appliance includes Inset Live Fuel Effect (ILFE) fires, radiant convector fires and boilers, in both room-sealed and open-flued variants.
- 4.8 The size of the free air supply to the combustion appliance should be in accordance with the provisions shown in Diagram 4.2.

### Example of calculation of free area of air vent using Diagram 4.2

- 4.9 An open-flued boiler with a rated input of 15 kW (net) is installed in an appliance compartment such as a boiler room, which is ventilated directly to the outside. The design of the boiler is such that it requires cooling air. In these circumstances –

The cooling air is exhausted via vent **D**, which has an area of –

$$15 \times 500 = 7500 \text{ mm}^2$$

The cooling air and the air needed for combustion and the safe operation of the flue enters via vent **E**, which has an area of –

$$15 \times 1000 = 15000 \text{ mm}^2$$

**Diagram 4.2 Free areas of permanently open air vents for gas appliance installations (other than decorative fuel effect fires or flueless appliances)**

see para 1.2, 4.7 & 4.8

vents at B, D, F and H are high level vents

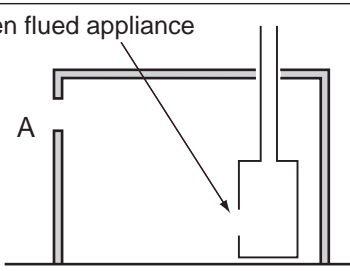
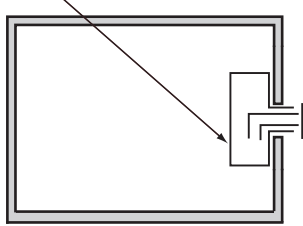
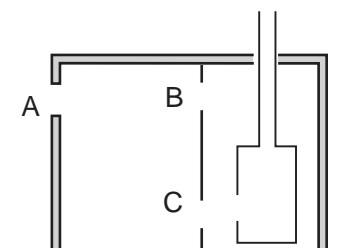
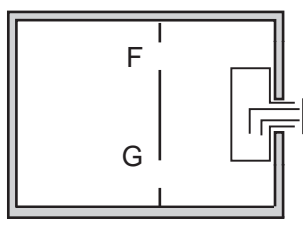
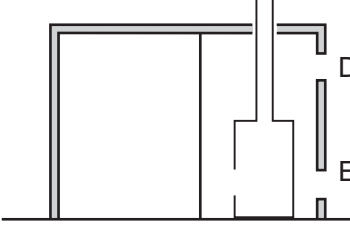
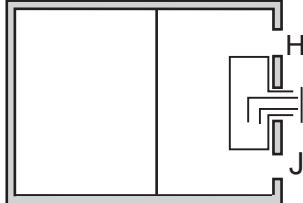
	<b>Open Flued</b>	<b>Room Sealed</b>
<b>Appliance in a room or space</b>	<p>Open flued appliance</p>  <p>A = 500 mm<sup>2</sup> per kW input (net)</p> <p style="text-align: center;"><b>Section</b></p>	<p>Room sealed appliance</p>  <p>No vent needed</p> <p style="text-align: center;"><b>Plan</b></p>
<b>Appliance in an appliance compartment ventilated via an adjoining room or space</b>	 <p>A = 500 mm<sup>2</sup> per kW input (net) in excess of 7 kW (see Note 3)                  B = 1000 mm<sup>2</sup> per kW input (net)                  C = 2000 mm<sup>2</sup> per kW input (net)</p> <p style="text-align: center;"><b>Section</b></p>	 <p>F = 1000 mm<sup>2</sup> per kW input (net)                  G = F</p> <p style="text-align: center;"><b>Plan</b></p>
<b>Appliance in an appliance compartment ventilated direct to outside</b>	 <p>D = 500 mm<sup>2</sup> per kW input (net)                  E = 1000 mm<sup>2</sup> per kW input (net)</p> <p style="text-align: center;"><b>Section</b></p>	 <p>H = 500 mm<sup>2</sup> per kW input (net)                  J = H</p> <p style="text-align: center;"><b>Plan</b></p>

**Notes:**

1. A, D, E, H and J are permanently open vents to the outside. B, C, F and G are permanently open vents between an appliance compartment and a room or space.
2. Calculations employ the appliance rated net heat input.
3. The area given above is the free area of the vent(s) or the equivalent free area for ventilators of more complex design.
4. Vents at C, E, G, and J are low level vents, Vents B, D, F and H are high level vents
5. In older dwellings with an air permeability which is more than 5.0 m<sup>3</sup>/h/m<sup>2</sup> the first 7 kW (net) can be ignored

## Flueless appliances

- 4.10 The ventilation for a flueless gas appliance **should** be provided in accordance with Table 4.1. For some flueless appliances, it may be necessary to provide permanently open air vents and/or make provision for rapid ventilation as recommended in BS 5440 - 2: 2009.
- 4.11 A room containing a gas point intended for use with a flueless appliance (such as a cooker, or space heater or water heater, with the gas point not adjacent to a flue) **should** have the ventilation provision calculated on the basis that an appliance with the largest rating consistent with Table 4.1 could be installed there.

**Table 4.1 Ventilation for flueless gas appliances**

Flueless appliance type	Maximum appliance rated heat input	Volume of room, space or internal space (m <sup>3</sup> ) <sup>(1)</sup>	Free area of permanently open air vent (mm <sup>2</sup> ) <sup>(2)</sup>
Cooker, oven hotplate or grill or combination thereof	Not applicable	< 5	10000
		5 to 10	5000 <sup>(4)</sup>
		> 10	no permanently open vent needed
Instantaneous water heater	11 kW (net)	< 5	Installation of water heater not permitted
		5 to 10	10000
		>10 to 20	5000
		> 20	no permanently open vent needed
Space heater not in an internal space <sup>(1)(2)</sup>	0.045 kW (net) per m <sup>3</sup> volume of room or space <sup>(3)</sup>	All cases	10000 PLUS 5500 per kW input (net) in excess of 2.7 kW (net)
Space heater in an internal space <sup>(1)(2)</sup>	0.090 kW (net) per m <sup>3</sup> volume of internal space	All cases	10000 PLUS 2750 per kW input (net) in excess of 5.4 kW (net)

Notes:

- (1) An internal space means one which communicates with several rooms or spaces, such as a hallway or landing.
- (2) For LPG fired space heaters conforming to BS EN 449: 2002+A1:2007 the recommendations of BS 5440-2: 2009 should be followed.
- (3) No permanent open air vent is required if the room or space has a door which opens directly to the outside.
- (4) **No permanent opening required if the room has a door that opens directly to outside**
5. The permanent ventilation provisions listed in this table are additional to the openable elements or (for kitchens only) extract ventilation in accordance with Part K.

Examples:

- a. Space heater in a lounge measuring 4 m x 4 m x 2.4 m = 38.4 m<sup>3</sup>, the appliance rated input should not be greater than 38.4 x 0.045 = 1.73 kW
- b. Space heater in a hallway with a rated input of 7 kW (net) should have a permanently open air vent with a free area of 10000 + 2750 x (7 - 5.4) = 14400 mm<sup>2</sup>

## Flues and chimneys

### Size of natural draught flues for open-flued appliances

- 4.12 A flue **should** be sized in accordance with Table 4.2 to suit the intended appliance and to ensure an adequate discharge velocity to prevent flow reversal problems but not to impose excessive flow resistance.
- 4.13 For an appliance that is CE marked as compliant with the Gas Appliances (Safety) Regulations 1995, the flue **should** be sized in accordance with the manufacturer's installation instructions.
- 4.14 The fluepipe **should** be the same size as the appliance flue outlet and the flue **should** have at least the same cross-sectional area as that of the appliance flue outlet.

**Table 4.2 Size of flues for gas-fired appliances**

Intended installation	Minimum flue size
Radiant/convector gas fire (new flue)	Circular - 125 mm diameter Rectangular - 16500 mm <sup>2</sup> cross-sectional area with a minimum side dimension of 90 mm
Radiant/convector gas fire (existing flue)	Circular - 125 mm diameter Rectangular - 12000 mm <sup>2</sup> cross-sectional area with a minimum side dimension of 63 mm
ILFE fire or DFE fire within a fireplace opening up to 500 mm x 550 mm	Circular or rectangular - Minimum flue dimension of 175 mm <sup>(1)</sup> (diameter and side)
DFE fire installed in a fireplace opening in excess of 500 mm x 550 mm	Calculate in accordance with Section 3, paragraph 3.7 to 3.8.
Note:	
(1) Some ILFE and DFE appliances are suitable for use with a circular flue with a diameter not less than 125 mm or a rectangular flue with a cross-sectional area of not less than 16500 mm <sup>2</sup> with a minimum side dimension of 90 mm.	

### Height of natural draught flues for open-flued appliances

- 4.15 A flue **should** be high enough to ensure sufficient draught to safely clear the products of combustion. For an appliance that is CE marked as compliant with the Gas Appliances (Safety) Regulations 1995, it **should** be installed in accordance with the manufacturer's installation instructions.
- 4.16 Where an older appliance that is not CE marked is to be used and it has no manufacturer's installation instructions it **should** be installed in accordance with –
- the recommendations in BS 5871 - 3: 2005 for decorative fuel effect (DFE) fires; or
  - the recommended calculation procedures in BS 5440 - 1: 2008 for appliances other than decorative fuel effect fires.

## Outlets from flues

- 4.17 The outlet from a flue **should** be so situated externally as to allow the safe dispersal of the products of combustion and, if a balanced flue, the intake of air. The flue outlet **should** be located as shown in Diagram 4.3, Table 4.3 and Diagram 4.4.
- 4.18 A flue serving a natural draught open-flued appliance, with a diameter not greater than 170 mm, **should** be fitted with an outlet terminal that complies with BS EN 1856-1:2003, **and conforms to BS EN 13502:2002**.
- 4.19 A flue serving a natural draught open-flued appliance, with a diameter greater than 170 mm, **should** be fitted with a protective cage designed for solid fuel use, having a mesh size not less than 6 mm and not greater than 25 mm. The total free area of the cage **should** be not less than twice the cross-sectional area of the flue.
- 4.20 A flue outlet **should** be protected with a guard if –
- a person could easily come into contact with it; and
  - it could be damaged.
- 4.21 If a flue outlet is in a vulnerable position, such as where it discharges at a point within reach of the ground, a balcony, a veranda or window, it **should** be designed to prevent the entry of any matter that could obstruct the flow.

**Diagram 4.3 Location of outlets from flues serving gas appliances**

see para 4.17  
see table 4.3

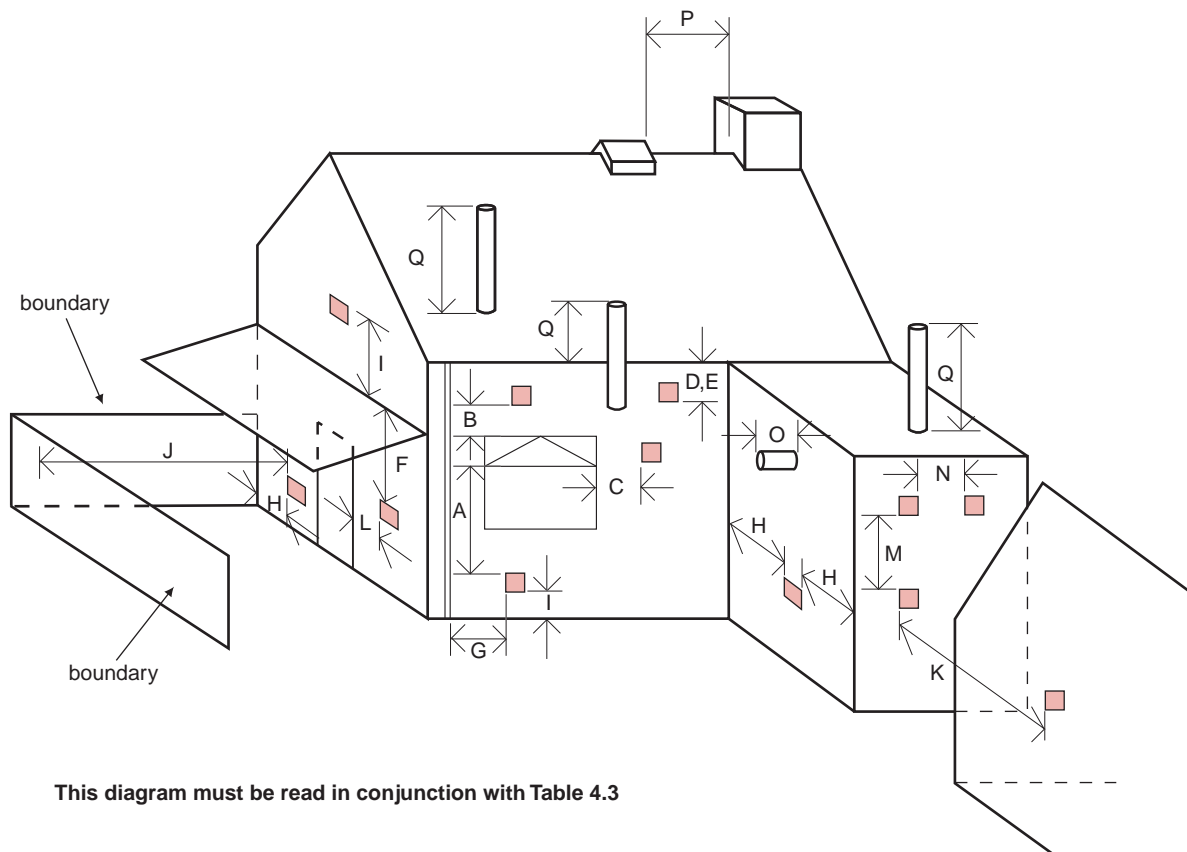

Table 4.3 Locations of flue outlets serving gas appliances

Distance	Location	Minimum separation distances for terminals (mm)			
		Balanced flue		Open flue	
		Natural draught	Fanned draught	Natural draught	Fanned draught
A	Below an opening <sup>(1)</sup>	Appliance rated heat input (net) 0 – 7 kW: 300 >7 – 14 kW: 600 >14 to 32 kW: 1500 > 32kW: 2000	300	Not to be used	300
B	Above an opening <sup>(1)</sup>	0 – 32 kW: 300 >32kW: 600	300	Not to be used	300
C	Horizontally to an opening <sup>(1)</sup>	0 – 7 kW: 300 >7 – 14kW: 400 > 14kW: 600	300	Not to be used	300
D	Below gutters, soil pipes or drains.	300	75	Not to be used	75
E	Below eaves	300	200	Not to be used	200
F	Below balcony or car park roof	600	200	Not to be used	200
G	From a vertical drain or soil pipe	300	150 <sup>(3)</sup>	Not to be used	150
H	From an internal or external corner or to a boundary alongside the terminal <sup>(2)</sup>	600	300	Not to be used	200
I	Above ground, roof or balcony level	300	300	Not to be used	300
J	From a surface or a boundary facing the terminal <sup>(2)</sup>	600	600	Not to be used	600
K	From a terminal facing the terminal	600	1200	Not to be used	1200
L	From an opening in the car port into a building	1200	1200	Not to be used	1200
M	Vertically from a terminal on the same wall	1500	1500	Not to be used	1500
N	Horizontally from a terminal on the same wall	300	300	Not to be used	300
O	From the wall on which the terminal is mounted	Not applicable	Not applicable	Not applicable	50
P	From a vertical structure on the roof	Not applicable	Not applicable	1500 if a ridge terminal. For any other terminal as per BE 5440 – 1: 2008	Not applicable
Q	Above the highest point of intersection with the roof	Not applicable	Site in accordance with manufacturer's instructions	Site in accordance with BS 5440 – 1: 2008	150

## Notes:

- (1) An opening here means an openable element, such as an openable window, or a fixed opening such as a vent. However, in addition, the outlet should not be nearer than 150 mm (fanned draught) or 300 mm (natural draught) to an opening into the building fabric formed for the purpose of accommodating a built in element, such as a window frame.
- (2) Smaller separations to the boundary may be acceptable for appliances that have been shown to operate safely with such separations from surfaces adjacent to or opposite the flue outlet.
- (3) This dimension may be reduced to 75 mm for an appliance with an input (net) not greater than 5 kW.

**Diagram 4.4 Location of outlets near roof windows or openings (from flues serving gas appliances)**

see para 4.17

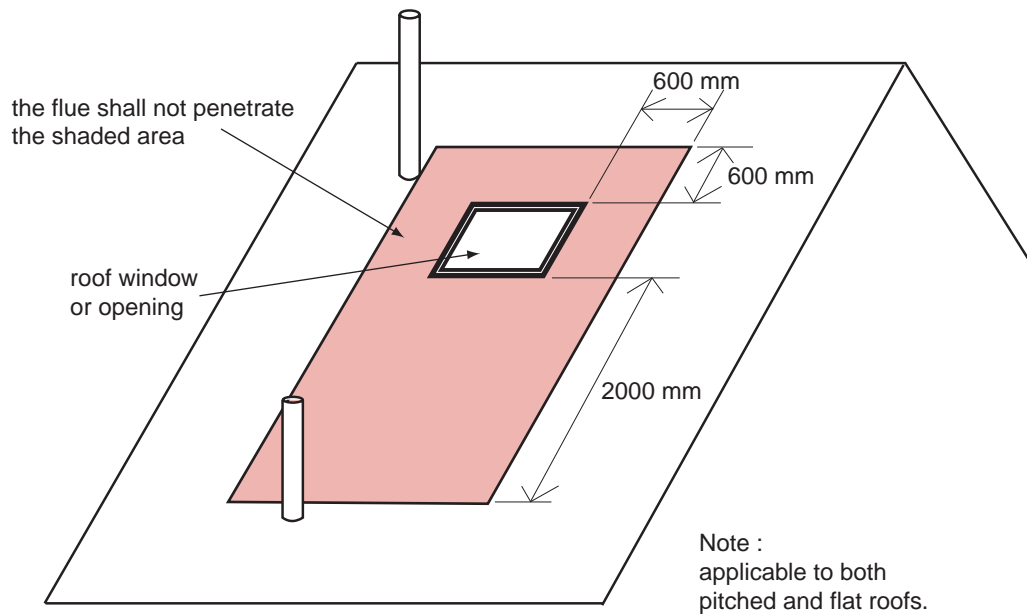

This diagram must be read in conjunction with Diagram 4.3 and Table 4.3

### Provision of flues

- 4.22 The flue and fluepipe for a gas appliances **should** –
- (a) be designed and constructed following the provisions on the selection of components and the manner of their installation as given in paragraphs 4.23 to 4.28 below; or
  - (b) if the intended appliance is new and of a known type –
    - (i) be built using factory-made components that have been independently certified as achieving a performance at least equal to that corresponding to the designation given in Table 4.4; and
    - (ii) be installed in accordance with the provisions of paragraphs 4.25 to 4.28 and Section 2, as relevant, and in accordance with the appliance manufacturer's and component manufacturer's installation instructions.

**Table 4.4 Minimum performance designations for chimney and fluepipe components for use with new gas appliances**

Appliance type		Minimum designation <sup>(1)(2)</sup>
Boiler: open-flue	Natural draught	T250 N2 D 1 O
	Fanned draught	T250 P2 D 1 O
	Condensing	T140 P2 W 1 O
Boiler: room-sealed	Natural draught	T250 N2 D 1 O
	Fanned draught	T250 P2 D 1 O
	Condensing	T140 P2 W 1 O
Gas fire	Radiant/convector, ILFE or DFE	T250 N2 D 1 O
Air heater	Natural draught	T250 N2 D 1 O
	Fanned draught	T250 P2 D 1 O
	SE-duct	T250 N2 D 1 O

Notes:

(1) The designation of chimney products is described in Appendix B. The BS EN for the product will specify its full designation and marking requirements.

(2) These are default designations. Where appliance manufacturer's installation instructions specify a higher designation, this should be complied with.

### Fluepipe components

- 4.23 The components for a fluepipe **should** be –
- any of the options in paragraph 2.26;
  - a sheet metal pipe as described in **BS EN1856-2:2004**;
  - a fibre cement pipe as described in **BS EN 1857:2003+A1:2008**; or
  - any other material or component that has been certified as suitable for this purpose.**

### Flueblock chimneys

- 4.24 A flueblock chimney **should** be constructed from either –
- a factory-made flueblock system primarily designed for solid fuel, as described in paragraphs 2.23 and 2.24; or
  - a factory-made flueblock system comprising of straight blocks, recess units, lintel blocks, offset blocks, transfer blocks and jointing materials complying with –
    - BS EN 1858:2008 for concrete flueblocks of at least class D2**; or
    - BS EN 1806:2006** for clay/ceramic flueblocks, with a performance class of at least FB4 N2.
- 4.25 A flueblock chimney **should** be installed with sealed joints in accordance with the flueblock manufacturer's installation instructions. Where bends or offsets are required, these **should** be formed using matching factory-made components. Flueblocks, which are not intended to be bonded into surrounding masonry, **should** be supported and restrained in accordance with the manufacturer's installation instructions.

## Location and shielding of flues

- 4.26 The combustible materials in the building fabric **should** be protected from the heat dissipation from a flue in accordance with the provisions of Table 4.5.
- 4.27 Where a fluepipe or flue penetrates a fire compartment wall or floor, it must not breach the fire separation requirements of Part E of the Building Regulations.
- 4.28 A fluepipe and factory-made chimney **should** be guarded where –
- they present a burn hazard to people that is not immediately apparent; or
  - they could be at risk of damage.

**Table 4.5 Protecting buildings from hot flues**

Flue gas within	Protection measures
Fluepipe	A flue <b>should</b> be not less than 25 mm from any combustible material, measured from the outer surface of the flue wall, or the outer surface of the inner wall in the case of multi-walled products. Where passing through a combustible wall, floor or roof (other than a compartment wall, floor or roof) a non-combustible sleeve enclosing the fluepipe or flue <b>should</b> be used which has a 25 mm airspace to the relevant flue wall. The airspace can be wholly or partially filled with non-combustible insulating material.
Factory - made chimney complying with BS EN 1856 - 1: 2003	
Factory - made chimney complying with - BS EN 1856 - 1: 2003 and <b>BS EN 1856 - 2: 2004</b>	Install in accordance with Section 1, Paragraph 2.37
Masonry chimney	Provide 25 mm of masonry between the flue and any combustible material
Flueblock chimney	Provide flueblock walls with a thickness of not less than 25 mm

## Lining or relining flues in chimneys

- 4.29 The lining or relining of a flue serving a gas appliance **should** be carried out in accordance with the provisions given in paragraphs 2.21, 2.22 and 3.20 or by using a flexible stainless steel liner independently certified as complying with BS EN 1856-1:2003 and BS EN 1856-2:2004.
- 4.30 A flexible metal flue liner **should** be installed in one complete length without joints within the chimney. Other than for sealing at the top and the bottom, the space between the chimney and the liner **should** be left empty unless this is contrary to the manufacturer's instructions.
- 4.31 Where a double skin flexible flue liner is used it **should** be installed in accordance with the manufacturer's installation instructions. A liner which complies with the recommendations of BS EN 1856 - 1: 2003 and BS EN 1856-2:2004, **should** be installed in accordance with BS 5440-1:2008.

### Debris collection space for chimneys

- 4.32 A debris collection space **should** be provided at the base of a chimney unless it is lined, constructed of flue blocks, or is a factory-made metal chimney with a flue box. The space **should** have a volume of not less than 12 litres and a depth of not less than 250 mm below the point where flue gases discharge into the flue. The space **should** be readily accessible for clearance of debris.

For gas fires of the type illustrated in Diagram 4.1(a) and (b), there **should** be at least 50 mm clearance between the end of the appliance spigot and any surface.

### Bases for back boilers

- 4.33 A back boiler **should** be adequately protected to shield the fabric of the building from heat by standing it on –
- (a) a hearth intended for a solid fuel appliance (see Diagram 3.7(a)); or
  - (b) unless otherwise stated in the manufacturer's instructions, a base complying with Diagram 4.5.

Diagram 4.5 Base for back boiler

see para 4.33

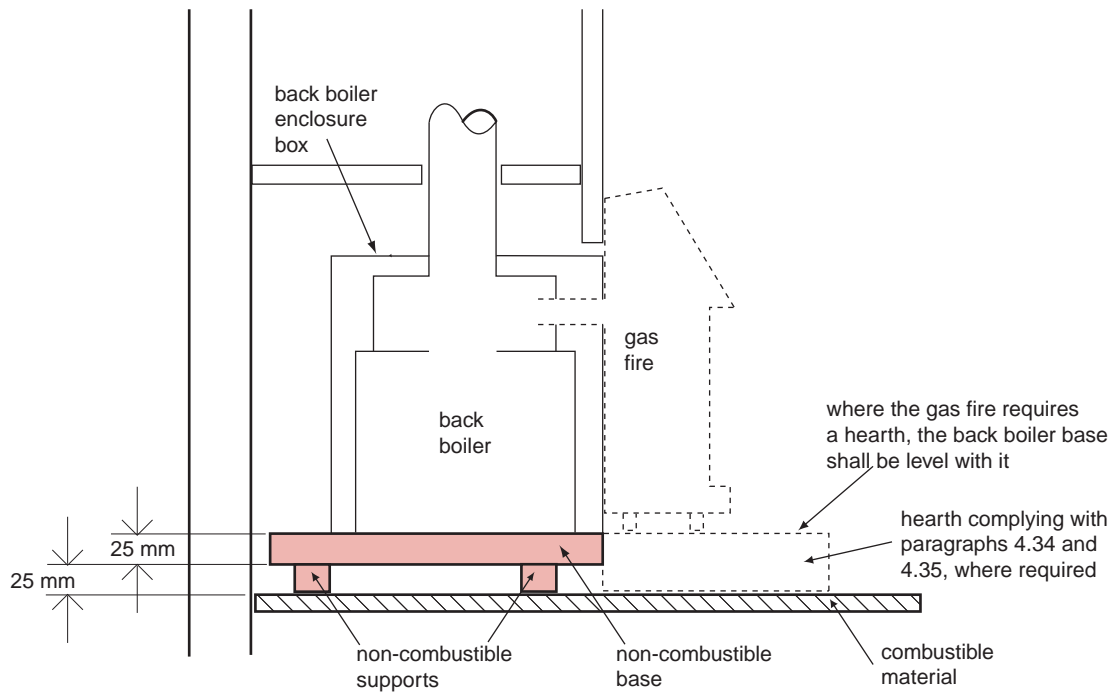

Section

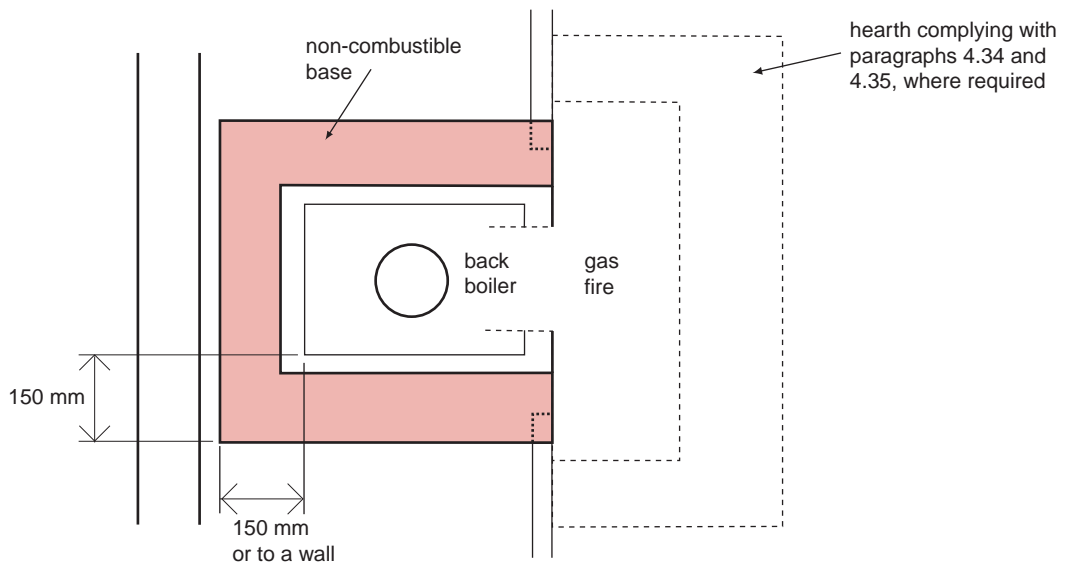

Plan

## Hearths for gas burning appliances

- 4.34 A gas-fired appliance **should** be placed on a hearth unless –
- (a) it is installed so that every part of any flame or incandescent material will be not less than 225 mm above the floor; or
  - (b) the manufacturer's instructions state that a hearth is not required.
- 4.35 Where a hearth is required, instructions on its minimum plan dimensions are given in Diagrams 4.6 and 4.7. The hearth **should** comprise of at least a layer of non-combustible, non-friable material not less than 12 mm thick. The edges of the hearth **should** be marked by a change in level to provide a warning to the building occupants and to discourage combustible floor finishes such as carpet being laid too close to the appliance.

**Diagram 4.6 Hearths for Decorative Fuel Effect (DFE) and Inset Live Fuel Effect (ILFE) fires: minimum plan dimensions of non-combustible surfaces**

see para 4.35

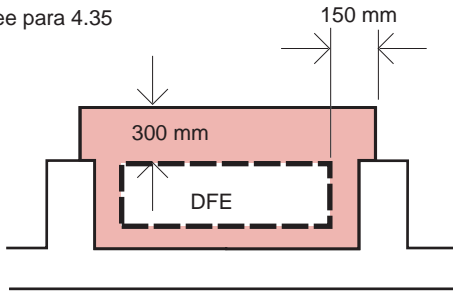

**Hearth projecting beyond fireplace recess**

**Plan**

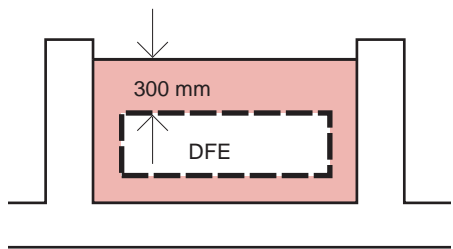

**Hearth contained entirely within fireplace recess**

**Plan**

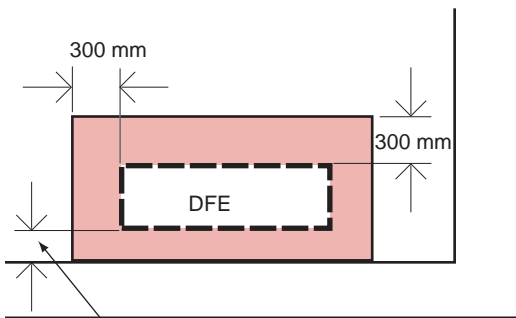

Less than 300 mm if hearth extends to a wall

**Free standing hearth**

**Plan**

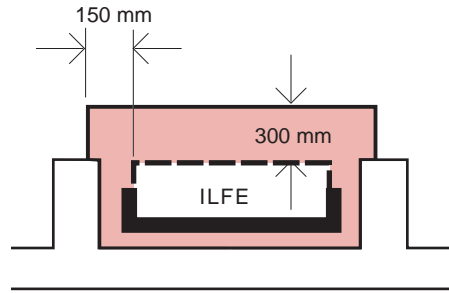

**Plan**

key

----- extent of incandescent part of fire (In some ILFE designs this may project beyond the fireplace opening)

■ surface to be kept free of combustible material

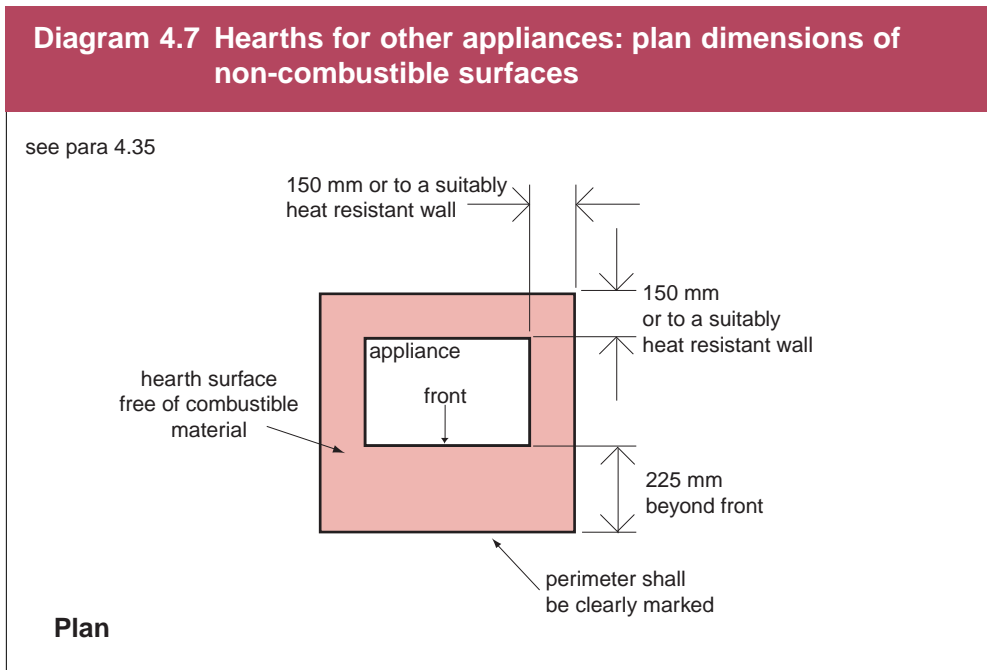

### Shielding of appliances

- 4.36 A gas-fired appliance **should** be located where accidental contact is unlikely and it **should** be surrounded by a non-combustible surface which provides adequate separation from combustible materials. The appliance **should** be installed –
- (a) with a shield of non-combustible material with a minimum thickness of 25 mm, between the appliance and the combustible material (see Diagram 4.8); or
  - (b) with an air space of not less than 75 mm between the appliance and the combustible material (see Diagram 4.8).
- 4.37 A gas-fired appliance that is CE marked as compliant with the Gas Appliances (Safety) Regulations 1995, **should** be installed in accordance with the manufacturer’s instructions.

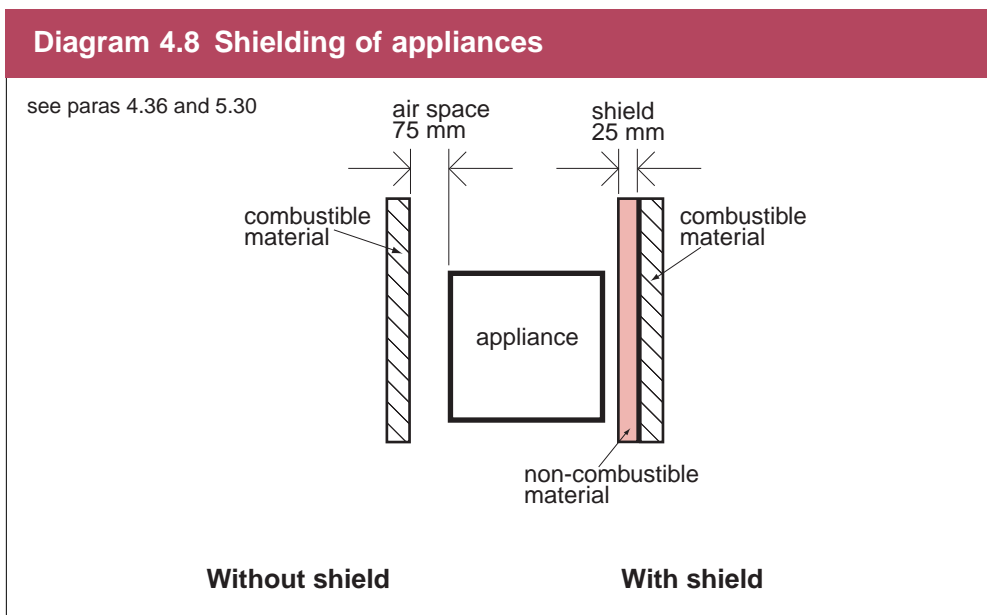

## Section 5 Oil burning appliances with a rated heat output up to 45 kW

This section sets out the additional provisions that **should** be met for oil burning appliances over and above those given in Section 2.

### Class of oil

- 5.1 The provisions in this Section are relevant to combustion installations designed to burn oils meeting the specifications for Class C2 (Kerosene) and Class D (Gas oil) given in BS 2869: 2010, liquid biofuel conforming to EN 14213:2003 and blends of mineral oil and liquid biofuel.

### Appliances fitted in bedrooms, bathrooms and shower rooms

- 5.2 An open-flued oil-fired appliance **should** not be installed in a bedroom, bathroom or shower room as there is an increased risk of carbon monoxide poisoning. If a combustion appliance must be installed in such a room then a room-sealed appliance **should** be provided.

### Air supply and ventilation

#### Air supply to appliances

- 5.3 The permanently open air vent for an oil burning appliance **should** have the free area as given in Diagram 5.1. However, if the manufacturer's installation instructions require a greater area of permanently open air vent then the manufacturer's advice **should** be followed.

#### Example of calculation of free area of air vent using Diagram 5.1

- 5.4 An open-flued appliance is installed in an appliance compartment such as a cupboard, which is ventilated via an adjoining room. The appliance has a rated output of 11 kW.

Air for combustion and the safe operation of the flue enters the adjoining room via vent **A**, which has an area –

$$(11 - 5) \times 550 = 3300 \text{ mm}^2$$

The cooling air for the appliance compartment is exhausted through vent **B** which has an area –

$$11 \times 1100 = 12100 \text{ mm}^2$$

All of the air for combustion and the safe operation of the flue as well as cooling air enters the appliance compartment through vent **C** which has an area –

$$11 \times 1650 = 18150 \text{ mm}^2$$

**Diagram 5.1 Free areas of permanently open air vents for oil fired appliance installations**

see para 5.3

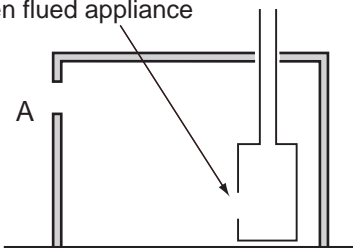
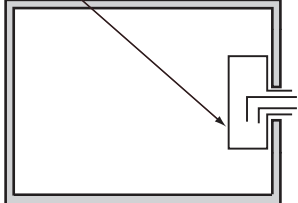
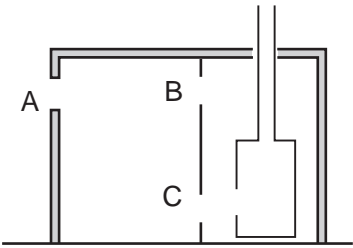
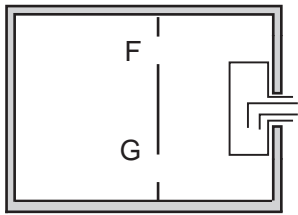
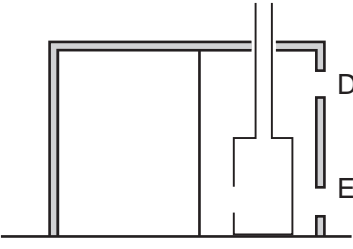
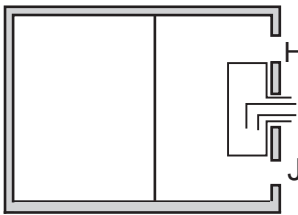
	<b>Open Flued</b>	<b>Room Sealed</b>
<b>Appliance in a room or space</b>	<p style="text-align: center;">Open flued appliance</p>  <p style="text-align: center;">A = 550 mm<sup>2</sup> per kW output (see Note 3 and 5)</p> <p style="text-align: center;"><b>Section</b></p>	<p style="text-align: center;">Room sealed appliance</p>  <p style="text-align: center;">No vent needed</p> <p style="text-align: center;"><b>Plan</b></p>
<b>Appliance in an appliance compartment ventilated via an adjoining room or space</b>	 <p style="text-align: center;">A = 550 mm<sup>2</sup> per kW output (see Note 3 and 5) B = 1100 mm<sup>2</sup> per kW output C = 1650 mm<sup>2</sup> per kW output</p> <p style="text-align: center;"><b>Section</b></p>	 <p style="text-align: center;">F = 1100 mm<sup>2</sup> per kW input (net) G = F</p> <p style="text-align: center;"><b>Plan</b></p>
<b>Appliance in an appliance compartment ventilated direct to outside</b>	 <p style="text-align: center;">D = 550 mm<sup>2</sup> per kW output E = 1100 mm<sup>2</sup> per kW output</p> <p style="text-align: center;"><b>Section</b></p>	 <p style="text-align: center;">H = 550 mm<sup>2</sup> per kW output J = H</p> <p style="text-align: center;"><b>Plan</b></p>

**Notes:**

1. A, D, E, H and J are permanently open vents to the outside. B, C, F and G are permanently open vents between an appliance compartment and a room or space.
2. The area given above is the free area of the vent(s) or the equivalent free area for ventilators of more complex design.
3. Vent A shall be increased by a further 550 mm<sup>2</sup> per kW output if the appliance is fitted with a draught break.
4. Vents at C, E, G, and J are low level vents.  
Vents at B, D, F, and H are high level vents.
5. In older dwellings with an air permeability which is more than 5.0 m<sup>3</sup>/h/m<sup>2</sup> the first 5 kW (net) can be ignored

## Flues and chimneys

### Size of flues (other than balanced flues and flues designed to discharge through or adjacent to walls)

- 5.5 A flue **should** be sized to suit the intended appliance such that it ensures an adequate discharge velocity to prevent flow reversal problems but does not impose excessive flow resistance.
- 5.6 The fluepipe **should** be the same size as the appliance flue outlet and the flue **should** be the same cross-sectional area as the appliance flue outlet unless the appliance manufacturer specifies otherwise.
- 5.7 The flue in a masonry or flueblock chimney **should** be the same size as the appliance flue outlet or of a larger size that will allow for the later insertion of a suitable flexible flue liner matching the appliance to be installed.

### Outlets from flues and flue heights

- 5.8 The outlet from a flue **should** be so situated externally as to allow the safe dispersal of the products of combustion, the correct operation of a natural draught flue and, if a balanced flue, the intake of air. The flue outlet **should** be located as shown in Diagram 5.2 and Table 5.1.
- 5.9 A flue outlet **should** be protected by a guard where –
- (a) a person could easily come into contact with it; or
  - (b) it could be damaged.
- 5.10 If a flue outlet is in a vulnerable position, such as where the flue discharges at a point within reach of the ground, a balcony, a veranda or window, it **should** be designed to prevent the entry of any matter that could obstruct the flow.

Diagram 5.2 Location of outlets from flues serving oil fired appliances

see para 5.8  
see table 5.1

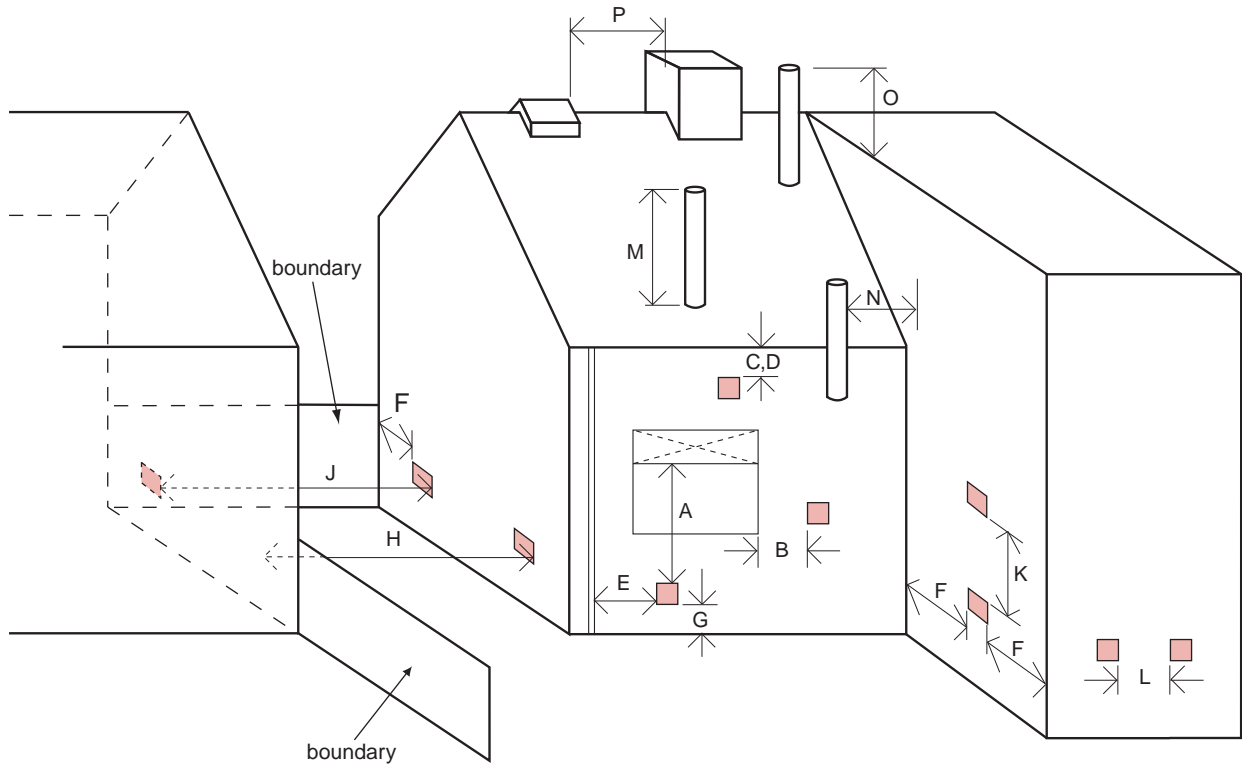

This diagram must be read in conjunction with Table 5.1

Table 5.1 Location of outlets for flues serving oil-fired appliances

Distance	Location of outlet <sup>(1)</sup> <sup>(2)</sup> <sup>(3)</sup>	Minimum separation distances for terminals (mm)	
		Appliance with pressure jet burner	Appliance with vaporising burner
A	Below an opening <sup>(4)</sup> <sup>(5)</sup>	600	Should not be used
B	Horizontally to an opening <sup>(4)</sup> <sup>(5)</sup>	600	Should not be used
C	Below a plastic/painted gutter, drainage pipe or eaves if combustible material is protected <sup>(6)</sup>	75	Should not be used
D	Below a plastic/painted gutter, drainage pipe or eaves if combustible material is not protected	600	Should not be used
E	From vertical sanitary pipework	300	Should not be used
F	From an external or internal corner or from a surface or boundary alongside the terminal	300	Should not be used
G	Above ground or balcony level	300	Should not be used
H	From a surface or boundary facing the terminal	600	Should not be used
J	From a terminal facing the terminal	1200	Should not be used
K	Vertically from a terminal on the same wall	1500	Should not be used
L	Horizontally from a terminal on the same wall	750	Should not be used
M	Above the highest point of an intersection with the roof	600 <sup>(8)</sup>	1000 <sup>(7)</sup>
N	From a vertical structure to the side of the terminal	750 <sup>(8)</sup>	2300
O	Above a vertical structure which is less than 750 mm (pressure jet) or 2300 mm (vaporising jet) horizontally from the side of the terminal	600 <sup>(8)</sup>	1000 <sup>(7)</sup>
P	From a ridge terminal to a vertical structure on the roof	1500	Should not be used

## Notes:

- (1) A terminal **should** only be positioned on a wall where an appliance has been approved for such configuration when tested in accordance with BS EN 303 – 1: 1999 or OFTEC standards OFS A100 or OFS A101.
- (2) The terminating point of any flue **should** be not less than 1800 mm from an oil storage tank unless a fire wall as described in Section 6 is provided between the tank and the flue termination.
- (3) A terminal **should** be positioned so as to avoid products of combustion accumulating in stagnant pockets around the building or entering into buildings.
- (4) An opening means an openable element, such as an openable window, or a permanent opening such as a permanent open air vent.
- (5) Notwithstanding the dimensions above, a terminal **should** be not less than 300 mm from combustible material, e.g. window frame.
- (6) Combustible material **should** be protected by the fitting of a heat shield at least 750 mm wide.
- (7) Where a terminal is used with a vaporising burner, it **should** be at least 2300 mm horizontally from the roof.
- (8) Outlets for vertical balanced flues in locations M, N and O **should** be in accordance with the manufacturers instructions.

## Flues for oil-fired appliances

- 5.11 The satisfactory provision of a flue and fluepipe depends upon the flue gas temperature to be expected in normal service. Separate **guidance is** given according to whether the proposed installation will have a flue gas temperature not greater than 250 °C, or greater than 250 °C, as measured, **for example**, in accordance with OFTEC Standards A100 or A101. **Suitable chimney systems may then be selected based on their performance designation having been tested in accordance with the relevant European standard.**
- 5.12 The flue gas temperature depends upon the appliance type and the age of its design. Older and second hand appliances are likely to produce flue gas temperatures greater than 250 °C.

Boilers bearing the CE marking, indicating compliance with the Boiler (Efficiency) Regulations 1993, normally have a flue gas temperature not greater than 250 °C. **Condensing oil-fired appliances will normally produce flue gas temperatures well below 100 °C.**

Information for individual appliances **should** be sought from the manufacturer's installation instructions, the manufacturer, or OFTEC.

Where this information is not available, a flue **should** be constructed for an assumed flue gas temperature greater than 250 °C.

### Provisions for flue gas temperatures greater than 250 °C

- 5.13 The chimney, flue and fluepipe for an oil burning appliance, with a flue gas temperature greater than 250 °C, **should** be –
- (a) in accordance with the provisions given in Sections 2 and 3 for a masonry or flueblock chimney; or
  - (b) a factory-made metal chimney in accordance with Section 2.

### Provisions for flue gas temperatures not greater than 250 °C

- 5.14 The chimney, flue and fluepipe for an oil burning appliance, with flue gas temperatures not greater than 250 °C, **should** –
- (a) be constructed in accordance with the provisions on the selection of components and the manner of their installation given in paragraphs 5.15 to 5.20; or
  - (b) if the intended appliance is of known type –
    - (i) be built using factory-made components that have been independently certified as achieving a performance at least equal to that corresponding to the designation given in Table 5.2 for the intended appliance type, when tested to an appropriate European chimney standard; and
    - (ii) be installed in accordance with the provisions of paragraphs 5.17 to 5.20 and Section 1, as relevant, and in accordance with the appliance manufacturer's and component manufacturer's installation instructions.

**Table 5.2 Minimum performance designations for chimney, flue and fluepipe components for use with new oil fired appliances with flue gas temperatures not greater than 250°C**

Appliance type	Fuel oil	Minimum designation
Condensing boiler, including combination boiler, range cooker, range cooker/boiler – with pressure-jet burners	Class C2 oil (kerosene) Liquid biofuel conforming to EN 14213:2003	T120 N2 W1 O
Condensing boiler, including combination boiler, range cooker, range cooker/boiler – with pressure-jet burners	Class D oil (heating oil)	T160 N2 W2 O
Non-condensing boiler, including combination boiler, range cooker, range cooker/boiler – with pressure-jet burners	Class C2 oil (kerosene) Liquid biofuel conforming to EN 14213:2003	T250 N2 D1 O
Non-condensing boiler, including combination boiler, range cooker, range cooker/boiler – with pressure-jet burners	Class D oil (heating oil)	T250 N2 D2 O
Cooker and room heater – with vaporising burner	Class C2 oil (kerosene)	T160 N2 D1 O
Cooker and room heater – with vaporising burner	Class D oil (heating oil)	T250 N2 D2 O

## Notes:

1. The designation of chimney products is described in Appendix B. The BS EN for the product will specify its full designation and marking requirements.
2. These are default designations. Where the appliance manufacturer's installation instructions specify a higher designation, this should be complied with.
3. Refer to the appliance manufacturer regarding the suitability of the appliance and flue system for use with oil / bio-liquid blends.

**Fluepipe components**

- 5.15 A fluepipe **should** be constructed using the following components –
- (a) any of the relevant options in paragraph 2.26;
  - (b) sheet metal as described in BS EN 1856-2:2004;
  - (c) fibre cement pipes as described in BS EN 1857:2003+A1:2008; or
  - (d) any other component that has been certified as suitable for this purpose.

**Flueblock chimneys**

- 5.16 A flueblock chimney **should** be constructed from either –
- (a) a factory-made flueblock system primarily designed for solid fuel, as described in paragraphs 2.23 and 2.24; or
  - (b) a factory-made flueblock system comprising of straight blocks, recess units, lintel blocks, offset blocks, transfer blocks and jointing materials complying with –
    - (i) BS EN 1858:2008 for concrete flueblocks; or
    - (ii) BS EN 1806:2006 for clay/ceramic flueblocks, with a performance not less than the designation given in Table 5.2 for the intended appliance type.

- 5.17 A flueblock chimney **should** be installed with sealed joints in accordance with the flueblock manufacturer's installation instructions. Where bends or offsets are required, these **should** be formed using matching factory-made components. Flueblocks that are not intended to be bonded into surrounding masonry **should** be supported and restrained in accordance with the manufacturer's installation instructions.

**Location and shielding of flues**

- 5.18 Where the flue gas temperature is not expected to exceed 250 °C the combustible materials in the building fabric **should** be protected from the heat dissipation from a flue in accordance with the provisions of Table 5.3.
- 5.19 Where a fluepipe or flue penetrates a fire compartment wall or floor, it must not breach the fire separation requirements of Part E of the Building Regulations.
- 5.20 A fluepipe flue and factory-made chimney **should** be guarded where –
- (a) they present a burn hazard to people that is not immediately apparent; or
  - (b) they could be at risk of damage.

**Table 5.3 Protecting buildings from hot flue gas temperatures not greater than 250°C**

Flue gas within	Protection measures
Fluepipe	A flue <b>should</b> be not less than 25 mm from any combustible material, measured from the outer surface of the flue wall, or the outer surface of the inner wall in the case of multi-walled products. Where passing through a combustible wall, floor or roof (other than a compartment wall, floor or roof) a non-combustible sleeve enclosing the fluepipe or chimney <b>should</b> be used which has a 25 mm airspace to the relevant flue wall. The airspace can be wholly or partially filled with non-combustible insulating material.
Factory-made chimney <b>designated in accordance with BS EN 1856-1:2003</b>	
Factory-made chimney <b>designated in accordance with BS EN 1856-1:2003 and BS EN 1856-2:2004</b>	Install in accordance with Section 2 paragraph 2.37 of this Technical Booklet
Masonry chimney	Provide not less than 25 mm of masonry between the flues and any combustible material
Flueblock chimney	Provide flueblock walls with a thickness of not less than 25 mm
Flue assemblies for room-sealed appliances	<ul style="list-style-type: none"> <li>(a) flues passing through combustible walls <b>should</b> be surrounded by insulation material not less than 50 mm thick.</li> <li>(b) provide a clearance of not less than 50 mm from the edge of the flue outlet to any combustible wall cladding.</li> </ul>

### Lining or relining flues in chimneys

- 5.21 Where the flue gas temperature is expected to be greater than 250 °C the liner **should** be –
- (a) as per the provisions in paragraph 2.22;
  - (b) as per the provisions in paragraph 3.20; or
  - (c) a flexible stainless steel liner **designated in accordance with BS EN 1858:2008**.
- 5.22 Where the flue gas is expected not to be greater than 250 °C the liner **should** be –
- (a) any of the linings described in 5.21 above; or
  - (b) if the appliance is new and of known type, flue lining systems that have been independently certified as having a performance not less than that corresponding to the designation given in Table 5.2 for the intended appliance type.
- 5.23 A flexible metal flue liner **should** be installed in one complete length without joints within the chimney. Other than for sealing at the top and the bottom, the space between the chimney and the liner **should** be left empty unless this is contrary to the manufacturer's instructions. Double skin flexible flue liners **should** be installed in accordance with manufacturer's installation instructions. BS 715: 1993 liners **should** be installed in accordance with BS 5440-1: 2000.

### Debris collection space for chimneys

- 5.24 A debris collection space **should** be provided at the base of a chimney unless it is lined or constructed of flue blocks, or is a factory-made metal chimney with a flue box. The space **should** have a volume of not less than 12 litres and a depth of not less than 250 mm below the point where flue gases discharge into the flue and be readily accessible for the clearance of debris.

### Flues for appliances burning Class D (Gas oil) fuel

- 5.25 A flue serving an appliance burning Class D (Gas oil) fuel **should** be made of materials which are resistant to the acids of sulphur, **i.e. minimum flue designation 'D2' for non-condensing appliances or 'W2' for condensing appliances, according to the designation system in BS EN 1443:2003 and related flue standards**.

### Hearths for oil fired appliances

- 5.26 Where an appropriate test procedure, such as in OFTEC Standards A100, A101 and A102, shows that the temperature of the floor below an appliance will not be greater than 100°C, a rigid, imperforate and non-absorbent sheet of non-combustible material, such as a steel tray, **should** be provided. This may be included as an integral part of the appliance.
- 5.27 Where the appliance will cause the temperature of the floor below it to be greater than 100 °C, a hearth of solid non-combustible material **should** be provided. It **should** –

- (a) have plan dimensions not less than those shown in Diagram 3.7; and
- (b) be made of solid non-combustible material, such as concrete or masonry, not less than 125 mm thick, including the thickness of any non-combustible floor and/or decorative surface.
- 5.28 Combustible materials **should** not be placed beneath a constructional hearth unless –
- (a) there is an air space of not less than 50 mm between the underside of the hearth and the combustible material; or
- (b) the combustible material is not less than 250 mm below the top of the hearth (see Diagram 3.8).
- 5.29 The appliance **should** not be placed closer to the edges of the hearth nor closer to any combustible material that is laid over the hearth than the distances shown in Diagram 5.3. The perimeter of this safe region **should** be marked by a change in level to provide a warning to the building occupants and to discourage combustible floor finishes such as carpet from being laid too close to the appliance.

**Diagram 5.3 Location of an oil-fired appliance in relation to its hearth. Minimum dimensions of the heat resistant material in the hearth and the clear zone of non-combustible surface**

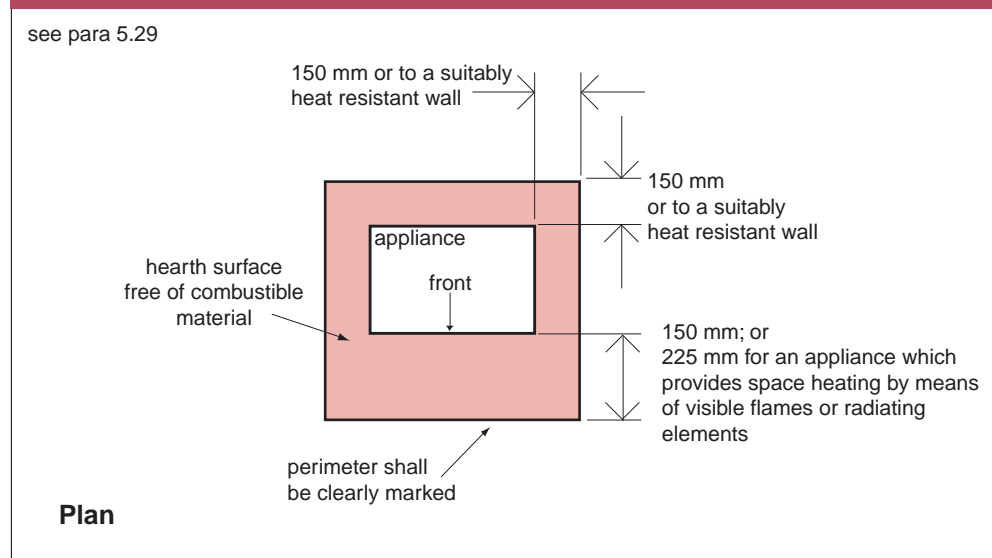

## Shielding of oil fired appliances

- 5.30 An oil fired appliance **should** be located where accidental contact is unlikely and it **should** be surrounded by a non-combustible surface which provides adequate separation from combustible materials. The appliance **should** be installed –
- (a) with a shield of non-combustible material, having a minimum thickness of 25 mm, between the appliance and the combustible material (see Diagram 4.8); or
- (b) with an air space of not less than 75 mm between the appliance and the combustible material (see Diagram 4.8).

- 5.31 An appliance independently certified as having a surface temperature, during normal operation of not greater than 100 °C (as shown using an appropriate test procedure such as in OFTEC Standards A100, A101 or A102) **should** not require shielding. Such certification **should** be prominently displayed on the appliance.

## Section 6 Liquid fuel storage and supply

### Oil storage installations

#### Heating oil

- 6.1 The provisions given in this part of the Section are related to heating oil that is Class C2 (kerosene) or Class D (gas oil) as specified in BS 2869:2010, liquid biofuel conforming to EN 14213:2003 and blends of mineral oil and liquid biofuel.

#### Protective measures against fire

- 6.2 An above ground oil storage tank **should** be placed on a hard surface constructed of concrete or paving slabs not less than 42 mm thick. The hard surface **should** extend beyond the perimeter of the tank, or its external skin if it is an integrally bunded type, by not less than 300 mm.

The protection of an above ground or semi-buried oil tank from a fire, which may start in a building or beyond the site boundary, **should** be in accordance with the provisions given in Table 6.1.

Detailed provisions for a buried tank are not given in this Technical Booklet but it should be installed in accordance with the recommendations of BS 5410:1997.

- 6.3 A firewall **should** be so constructed that it does not pose a danger to people around it.

#### Automatic isolation

- 6.4 The fuel pipework **should** be resistant to the effects of fire and be fitted with a fire valve system where it enters the building, in accordance with the relevant recommendations in BS 5410 Part 1:1997, Sections 8.2 and 8.3.

**Table 6.1 Fire protection for oil storage tanks**

Location of tank	Protective measures
1800 mm or more from a building	No protection required
Less than 1800 mm from any part of a building	Any eaves less than 1800 mm from the tank <b>should</b> have 30 minutes fire resistance for integrity and insulation extending 300 mm beyond each side of the tank, and either <ol style="list-style-type: none"> <li>any part of the building wall less than 1800 mm from the tank <b>should</b> be imperforate<sup>(1)</sup> with a minimum 30 minutes fire resistance in terms of insulation, integrity and stability to internal fire ; or</li> <li>provide a firewall <sup>(2)</sup> between the tank and any part of the building which is less than 1800 mm from the tank. The fire wall <b>should</b> extend not less than 300 mm higher and 300 mm wider than the tank.</li> </ol>
750 mm or more from a boundary	No protection required
Less than 750 mm from a boundary	Provide a fire wall <sup>(2)</sup> between the tank and the boundary or a boundary wall, which has a minimum of 30 minutes fire resistance in terms of insulation, integrity and stability to fire on either side. The fire wall or fire resistant boundary wall must extend not less than 300 mm higher and 300 mm beyond the ends of the tank.

**Note:**

- (1) Excluding small openings such as air bricks etc.
- (2) Firewalls **should** be imperforate non-combustible walls or screens, such as a masonry wall or fire-rated composite panel screens
3. The terminating point of any flue **should** be not less than 1800 mm from an oil storage tank unless a fire wall as described in (b) above is provided between the tank and the flue termination.

**Control of oil pollution**

- 6.5 Where Regulation L7 applies, the oil **should** be stored in an integrally banded prefabricated tank. The bund **should** have a capacity of not less than 110% of the tank it contains.

**Oil tank construction**

- 6.6 An oil storage tank **should** be constructed in accordance with the recommendations of OFS T100:2008 for polyethylene oil storage tanks or OFS T200:2010 for steel oil storage tanks.

## Liquefied Petroleum Gas (LPG) storage installations

The provisions in this part of the Section are limited to LPG storage installations with a capacity not greater than 1.1 tonne.

### Tank location and protective measures

- 6.7 An LPG storage installation with a capacity not greater than 1.1 tonne, comprising of one tank standing in the open air, **should** be installed in accordance with the LP Gas Association, Code of Practice 1: Bulk LPG Storage at Fixed Installations: Part 1(2009), and the following paragraphs.
- 6.8 The LPG tank **should** be installed in the open air and not within an open pit. The tank **should** be adequately separated from buildings, the boundary and any fixed sources of ignition to enable safe dispersal of the gas in the event of venting or leaks. If there is a fire at any of these locations these measures will reduce the risk of the fire spreading.
- 6.9 The tank **should** be placed so that the minimum separation distances given in Table 6.2 and shown in Diagram 6.1 are achieved. Drains, gullies and cellar hatches within the separation distances **should** be protected from gas entry.
- 6.10 The LPG tank **should** be sited such that there is a clear line of sight between the tank and the delivery vehicle to ensure that the person in control of the product transfer can quickly detect any problem at either point. If this cannot be achieved a remote fill point for the tank **should** be provided in clear view of the point at which the delivery vehicle is normally parked.
- 6.11 Combustible materials, including weeds, long grass, deciduous shrubs and trees, **should** be removed from an area around the tank for a distance equal to that given in Table 6.2, Column (B).
- 6.12 Where a visual screen is to be erected to hide an LPG tank, (e.g. at domestic installations), it **should** not interfere with the ventilation and shall only be located at one side of the tank. For the purpose of such screening, any evergreen shrubs, trees or a non-flammable open ranch type fence **should** be located at a distance equal to that given in Table 6.2, Column (B) from the tank.

### Firewalls for LPG installations

- 6.13 Where a firewall is part of a building or a boundary wall it **should** be located in accordance with Diagram 6.1(c) and if part of a building it **should** be constructed in accordance with Diagram 6.1(d).
- 6.14 A firewall **should** be imperforate and substantially constructed from brick, concrete or solid masonry. It shall have a fire resistance (insulation, integrity and stability) of not less than 30 minutes, but where it forms part of a building, 60 minutes fire resistance.

- 6.15 A firewall **should** be not less than the height of the pressure release valve and shall extend horizontally such that the separation distance specified in Table 6.2, Column (B) is maintained -
- (a) when measured around the ends of the firewall as shown in Diagram 6.1(b); or
  - (b) when measured to the ends of the firewall as shown in Diagram 6.1(c), if the firewall is the boundary or part of the building.

**Table 6.2 Fire protection for LPG storage tanks**

Capacity of tank (tonnes)	Minimum separation distances from buildings, boundaries or fixed sources of ignition (mm)	
	To a tank with no firewall or to a tank around a firewall	To a tank shielded by a firewall
(A)	(B)	(C)
Not more than 0.25	2500	300
More than 0.25 but not more than 1.10	3000	1500

**Diagram 6.1 Separation or shielding of liquified petroleum gas tanks of up to 1.1 tonne capacity from buildings, boundaries and fixed sources of ignition**

see para 6.9, 6.13 and 6.15 (a) & (b)  
see table 6.2 columns (B) & (C)

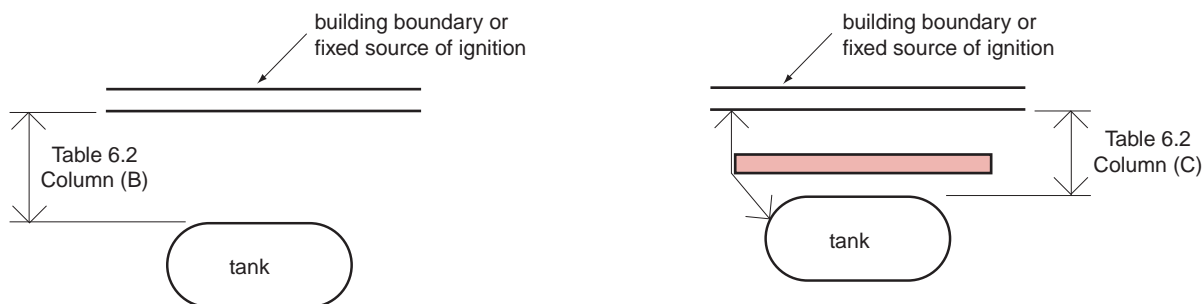

**(a) No fire wall**

**(b) Separate fire wall**

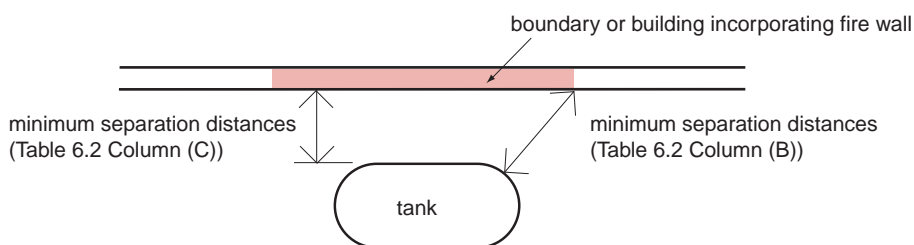

**(c) Boundary incorporating firewall  
or  
Building incorporating firewall  
(see also Diagram (d) below)**

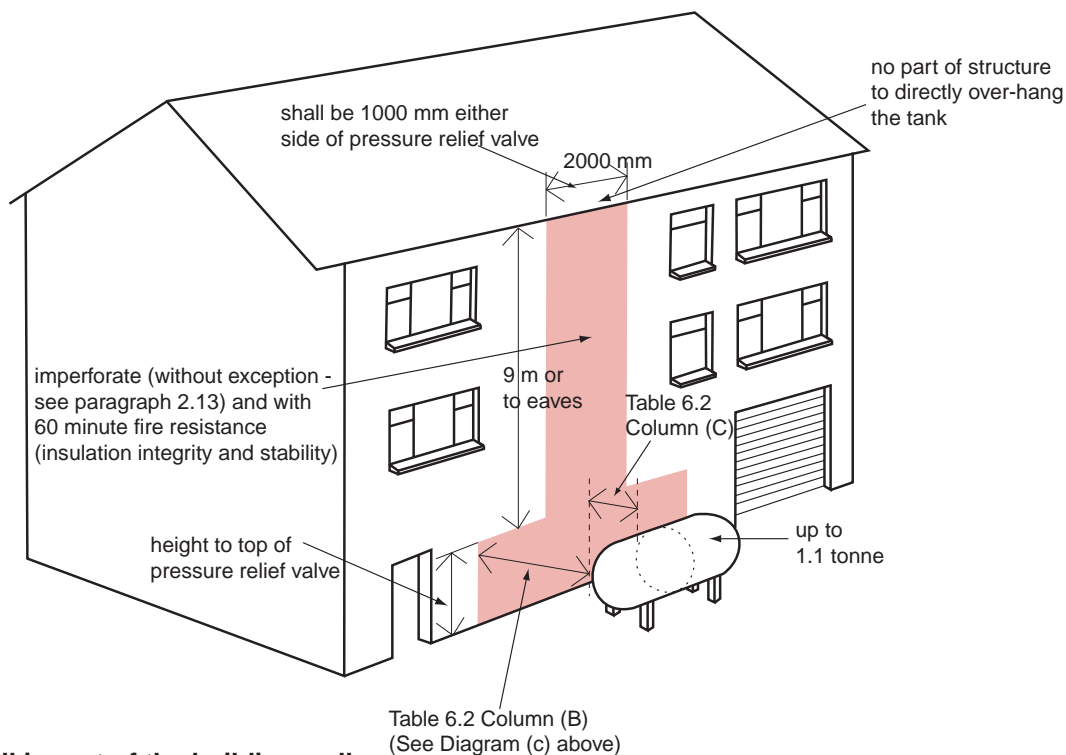

**(d) Fire wall is part of the building wall**

## Location and support of LPG cylinders

- 6.16 Where an LPG storage installation consists of a set of cylinders, the provisions shown in Diagram 6.2 **should** be followed.
- 6.17 A cylinder **should** stand upright, be secured by straps or chains against a wall outside the building in a well ventilated position at ground level. It **should** be readily accessible, reasonably protected from physical damage and located where it does not obstruct exit routes from the building. A firm level base, such as concrete not less than 50 mm thick or paving slabs bedded on mortar **should** be provided. The cylinder valves **should** be not less than -
- 1000 mm horizontally and 300 mm vertically from openings in the building or heat sources such as flue terminals and tumble-dryer vents; and
  - 2000 mm horizontally from drains without traps, unsealed gullies and cellar hatches, unless an intervening wall not less than 250 mm high is provided.

**Diagram 6.2 Location of LPG cylinders**

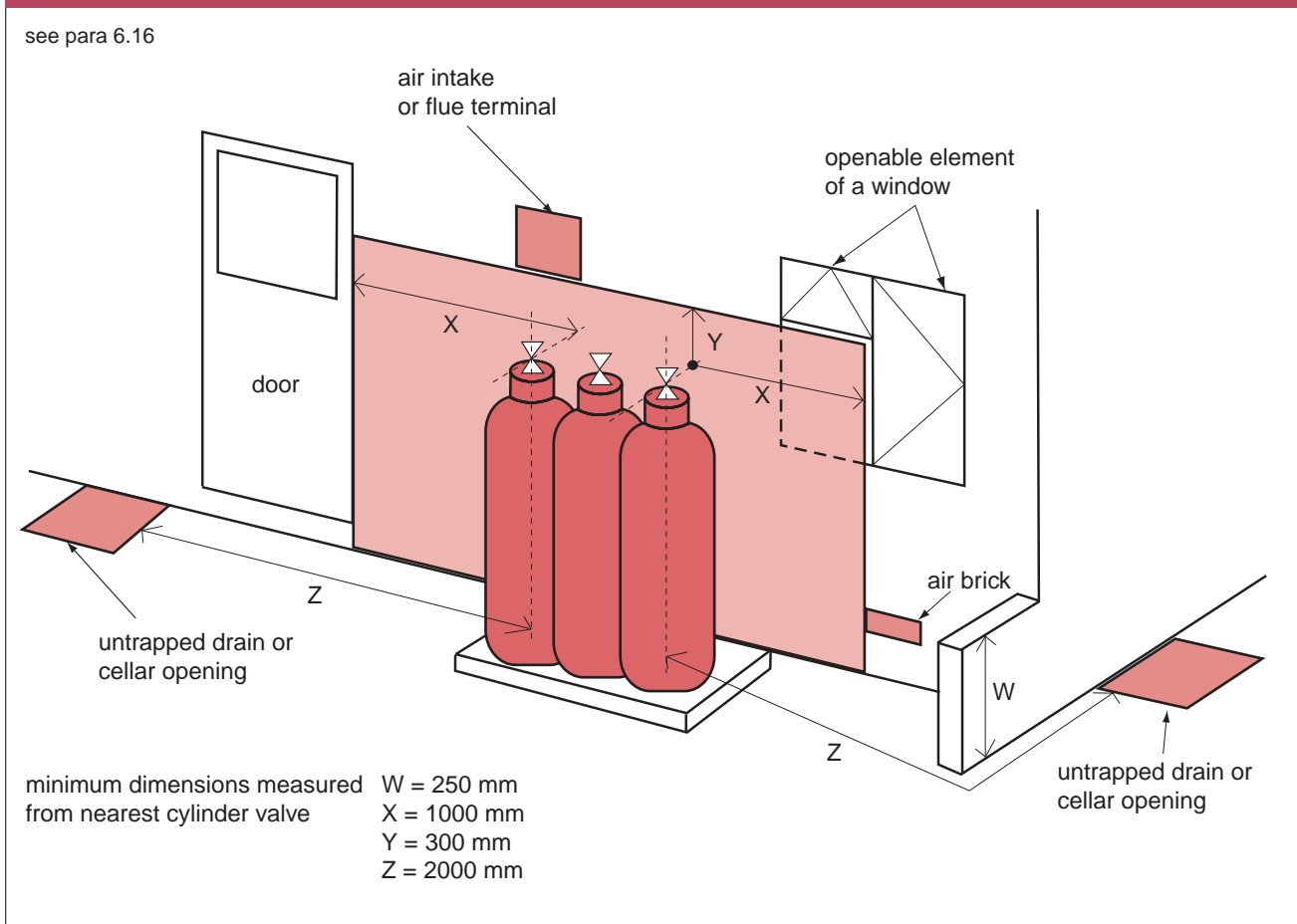

## Appendix A Inspection and testing of flues, chimneys and fluepipes

- A.1 This Appendix only describes ways of checking a natural draught flue intended for open-flued appliances. The procedures described are only used to assess whether the flue in the chimney, the connecting fluepipe (and flue gas passages in the appliance) are free of obstruction and acceptably gas-tight. In addition, appliance performance tests, including flue spillage tests must be carried out when a gas-fired appliance is commissioned as required by the Gas Safety (Installation and Use) Regulations (Northern Ireland) 2004.
- A.2 Tests on flues should be carried out at the most appropriate time during the building work. Where possible smoke tests shall be performed when the structure of a chimney is visible and before the application of finishes such as plaster or dry lining that could obscure sight of smoke leakage during testing.

### Inspection

#### Existing flues

- A.3 A flue in an existing chimney can be obstructed by nests, debris resulting from deterioration of the structure (e.g. brickwork, flue lining material or pieces of chimney pot) and by soot and tar. A flue in an existing chimney may also leak as a result of holes or cracks appearing in the structure and linings, particularly at joints. The top, exposed part of a chimney is particularly prone to decay.
- A.4 Prior to bringing a flue back into use, it should be checked by -
- (a) Sweeping the flue. This is intended to clean the flue to demonstrate that it is essentially free from obstructions and to enable better visual inspection and testing of the flue. Tar deposits caused by burning wood may be especially hard to dislodge and must be removed. The debris that comes down the chimney when sweeping should be examined for excessive quantities of lining or brick that are signs that further repairs are necessary.
  - (b) Carrying out a visual inspection of the accessible parts to identify –
    - (i) deterioration in the structure, connections or linings which could affect the flue's gas-tightness and safe performance with the proposed combustion appliance. Examine the interior of the flue and the exterior of the chimney, including in the roof space. The presence of smoke or tar stains on the exterior of a chimney are signs of leaks that indicate damage;
    - (ii) modifications made whilst the flue was out of service, such as the fitting of a ventilator terminal, which would be incompatible with using the flue with the intended appliance; and
    - (iii) correct lining and lining sizes for the proposed new application.

- (c) Perform checks where necessary to demonstrate that the flue is free from restriction. A visual check may be sufficient where the full length of the flue can be seen. In cases of doubt, a coring ball test should be carried out.
- (d) Check the operation and gas tightness of the flue by carrying out a smoke test.

### **New masonry and flueblock chimneys**

- A.5 Check during construction that liners are installed the right way up; with sockets facing upwards, and joints are sealed so that moisture and condensate will be contained in the chimney.
- A.6 A flue in a new masonry chimney can be obstructed, particularly at bends, by debris left during construction, or by excess mortar falling into the flue or by jointing material extruded from between liners and flueblocks. The flue must be checked to demonstrate that it has been correctly constructed and is free of restrictions and acceptably gas-tight. The condition of a new flue prior to bringing it into use must be checked by –
  - (a) visually inspecting the accessible parts to check that the lining, liners or flueblocks are of the correct materials and of suitable size for the proposed application;
  - (b) performing checks where necessary to demonstrate that the flue is free from restriction. A visual check may be sufficient where the full length of the flue can be seen. In cases of doubt, a coring ball test should be carried out, or the flue swept, which may be more effective at removing flexible debris that might not be dislodged by a coring ball; and
  - (c) checking the operation and gas-tightness of the flue by carrying out a smoke test.

### **New factory-made metal chimneys**

- A.7 A checklist for the visual inspection of a newly completed factory-made metal chimney is given in **BS EN 15287-1:2007** and additional checks or particular variants may be included in manufacturers installation instructions. Following inspection, the chimney should be subjected to a smoke test.

### **Relined flues**

- A.8 A flue which has been relined should be checked to show that it is free from restrictions, such as from surplus material and that it is acceptably gastight by using the same tests as would be applied in the case of a newly built flue. However, a flue that has been relined with a flexible metal liner in accordance with Section 3 of this Technical Booklet may be assumed to be unobstructed and acceptably gastight. It should be noted that the use of a coring ball or inappropriate sweeps brushes could seriously damage a flexible metal flue liner.

## Appliances

- A.9 Where a combustion appliance is provided and connected up to the flue system as part of the work, the complete system of appliance and flue should be tested for gas tightness in addition to testing the flue separately as above. For gas-fired appliances an appropriate spillage test procedure is given in BS 5440 Part 1:2008 and for oil and solid fuel fired appliances suitable test procedures are given in BS 5410 Part 1:1997 and BS EN 15287-1:2007 Annex O respectively.

## Flue test procedures

### Coring ball test

- A.10 This test may be appropriate for proving the minimum diameter of circular flues. It may also be used to check for obstructions in square flues but will not detect obstructions in the corners. (A purpose made coring ball or plate may need to be used if the flue is rectangular.) It is not applicable to fluepipes and shall not be used with flexible metal flue liners. It should be carried out before smoke testing.
- A.11 A heavy ball, with a diameter about 25 mm less than that of the flue, is lowered on a rope from the flue outlet to the bottom of the flue. If an obstruction is encountered, the blockage should be removed and the test repeated.

### Smoke testing

- A.12 Where an existing flue is to be checked with a smoke test, it should first be swept.
- A.13 Two smoke testing procedures are described below –
- (a) Test I confirms the gastightness of the whole flue and may be used for one serving a solid fuel or oil fired appliance or if there is any doubt over the condition of a gas flue; or
  - (b) Test II may be used where the flue is to serve a gas-fired appliance.

Neither test is a substitute for any spillage test required when commissioning the appliance. Other smoke testing procedures could be used where these form part of the procedure for the installation of an approved flue or relining system.

### Smoke test I

- A.14 All doors and windows in the room served by the flue must be closed. The flue should first be warmed to establish a draught, e.g. with a blowlamp or electric heater. A suitable number of flue testing smoke pellets are placed at the base of the flue, such as in the fireplace recess or in the appliance if it is fitted, and ignited. When smoke starts to form, the base of the flue or fireplace opening must be sealed or the appliance closed, so that the smoke can only enter the flue. (For example, the recess opening should be closed off with a board or plate, sealed at the edges or, if the pellets are in the appliance, its doors, ashpit covers and vents should be closed).

- A.15 Smoke should be seen to issue freely from the flue outlet or terminal. When this is established, the top of the flue should be sealed. The full length of the flue should then be checked, bearing in mind paragraph B.20, there should be no significant leakage. The test should be allowed to continue for at least 5 minutes. The closures at the top and bottom of the flue should then be removed.

### **Smoke test II**

- A.16 All doors and windows in the room served by the flue must be closed. The flue should first be warmed to establish a draught. A suitable flue testing smoke pellet is ignited at the base of the flue or in the intended position of the appliance, so that the smoke is drawn into the flue with the rising draught. (If the pellets are placed in a recess at the base of the flue, the opening between the room and the recess should be partially closed, such as with a board, but an air entry gap of about 25 mm should be left at the bottom).
- A.17 Smoke should be seen to issue freely from the flue outlet or terminal and not to spill back into the room. There should be no significant leakage of smoke from the length of the chimney inside or outside of the building.
- A.18 Smoke tests I and II are in line with the recommendations in BS 5440 Part 1:2008.

### **Notes in relation to testing**

- A.19 Where warming of the flue is specified, this is intended to establish a draught, but this may take more than 10 minutes in the case of large or cold flues.
- A.20 Appliances, where fitted, should not be under fire at the time of carrying out the test. During a smoke test, smoke should not emerge from the outlet of any other flue, as this indicates leakage between flues. When checking for smoke leakage from a flue it should be borne in mind that smoke from a faulty flue can emerge some distance away from the original fault. In such cases, the smoke could emerge from such places as barge overhangs in end of terrace dwellings or from window reveals in cavity walls.
- A.21 The purpose of carrying out smoke testing is to check that flue gases will rise freely through the flue and to identify whether there are any faults, such as incorrectly sealed joints or damage that would cause the flue gases to escape into the dwelling.
- A.22 It should be noted that smoke pellets create a pressure significantly higher than the pressure required in the product standards for natural draught chimneys and for flues having a gas-tightness designation of N1. Flues to this designation are permitted to have a leakage rate of up to 2 litre/s/m<sup>2</sup> flue wall area. Some smoke leakage may therefore be seen during smoke tests and it can be a matter of expert judgment of whether leakage indicates failure.

## Appendix B European chimney designations

- B.1 This informative appendix provides a summary of the European chimney designation scheme. The essence of the scheme is a series of code letters based on the general chimney designation scheme of BS EN 1443:2003, an example of which and their explanation is given below.

### Designation

- B.2 The designation of a chimney consists of –

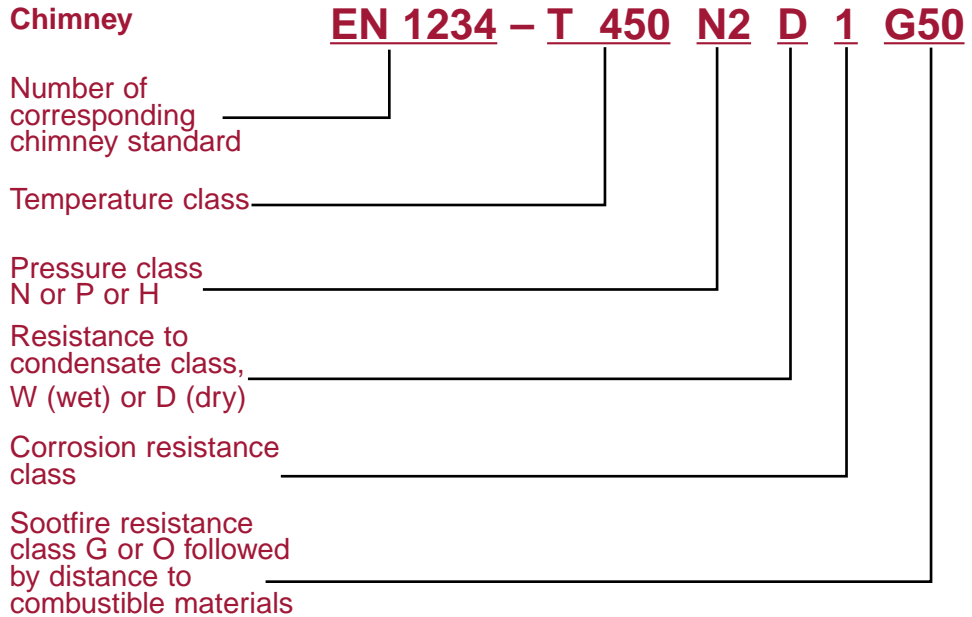

- B.3 European chimney standards have been developed based on the material of the flue liner e.g. clay/ceramic, concrete, metal, and plastic. Some material based standards have adopted a different shortened designation e.g. for clay flue liners a designation Liner – EN 1457-300-A1-N2 means it is suitable for a chimney with the designation T600 N2 D 3 G, with a nominal size of 300mm.
- B.4 The designation of the corrosion resistance class of a metal chimney product is dealt with in BS EN 1856-1 and BS EN 1856-2 by a two-fold approach. A minimum material specification and thickness is allowed which is dependent on that which is permitted in member states regulations, where these exist. Products upon which a declaration has been made in this manner are designated Vm. The alternative approach involves the choice of one of three corrosion resistance tests. Products meeting the tests carry the designation V1, V2 or V3, as appropriate allow the product to be designated with the Corrosion resistance class 1, 2, or 3 respectively. The material specification still forms part of the overall designation, and appears alongside the 'V' letter, e.g. Vx-L40045. The material specification for the liner (or connecting pipe) is formed by the letter 'L' followed by five digits. The first two digits represent the material type and the last three digits represent the material thickness in multiples of 0.01mm.

- B.5 For the UK, guidance on the minimum material specification appropriate for the various applications in terms of corrosion resistance (solid fuel, gas and oil) is given in the UK National Annex to BS EN 1856-1 and 2. For further examples of shortened designation refer to the specific product standards.
- B.6 In selecting an appliance for a given chimney designation, the appliance, irrespective of the fuel used, is required to generate combustion products with characteristics equal or less than those designated for the chimney. When selecting a chimney suitable for a given appliance, any chimney with performance characteristics equal to or higher than those appropriate for the appliance may be used.

### Temperature classes

- B.7 Temperature classes are set out in Table B1 and expressed as 'T' followed by a number which is less than or equal to the nominal working temperature, i.e. the average flue gas temperature obtained during the nominal/rated output test (usually the maximum operating level);

Table B1	
Temperature class	Normal working temperature is less than or equal to °C
T080	80 °C
T100	100 °C
T120	120 °C
T140	140 °C
T160	160 °C
T200	200 °C
T250	250 °C
T300	300 °C
T400	400 °C
T450	450 °C
T600	600 °C

## Pressure classes

- B.8 Pressure classes are set out in Table B2 and expressed as either 'N', 'P' or 'H' followed by either '1' or '2'. N relates in general to natural draught chimneys i.e. operating under negative pressure where the value 1 or 2 allows for a different class of product; metal chimneys to BS EN 1856-1 have the class N1. In the UK the value N2 will be assigned as a minimum to masonry chimneys. P and H relate to chimneys which operate under positive pressure e.g. for fan assisted applications and diesel generators respectively. The pressure designation depends on the gas tightness it achieves, the lower number being the more onerous, the higher allowed leakage for positive pressure application being intended to external installations.

Table B2 Pressure classes		
Pressure class	Test pressure Pa	Gas tightness Maximum leakage rate L/s/m <sup>2</sup>
N1	40	2.0
N2	20	3.0
P1	200	0.006
P2	200	0.120
H1	5000	0.006
H2	5000	0.120

## Condensate resistance classes

- B.9 Condensate resistance class – expressed as either 'W' for wet or 'D' for dry operations. A product designated 'W', able to contain condensates within the flue, is aimed at condensing appliances. A product designated 'D' would usually have flue gas temperatures high enough to avoid condensate formation.

## Sootfire resistance classes

- B.10 Sootfire resistance class – expressed as either 'G' with sootfire resistance, or 'O' without. A product assigned the designation 'G' has been tested at 1000 °C for 30 minutes.

## Distance to combustible material

- B.11 The designation of the minimum distance from the outer surface of the chimney to combustible material is given as xx expressed in millimetres (e.g. the distance 'x-x' identified in paragraph 2.37 and Diagram 2.5).

**Corrosion resistance classes**

B.12 Corrosion resistance classes are set out in Table B3 – this is fuel dependant and expressed as 1, 2 or 3.

**Table B3 Corrosion resistance classes (from BS EN 1443-2003)**

<b>Corrosion resistance class</b>	<b>1 Possible fuel types</b>	<b>2 Possible fuel types</b>	<b>3 Possible fuel types</b>
gas	Gas: sulphur content ≤ 50 mg/m <sup>3</sup> Natural gas L + H	Gas Natural gas L + H	Gas Natural gas L + H
liquid	Kerosene: sulphur-content ≤50 mg/m <sup>3</sup>	Oil: sulphur-content ≤0.2 mass % kerosene: sulphur-content ≥50 mg/m <sup>3</sup>	Oil: sulphur-content > 0.2 mass % kerosene: sulphur-content ≥50 mg/m <sup>3</sup>
wood	—	Wood in open fire places	Wood in open fire places Wood in closed stoves
coal	—	—	Coal
Peat	—	—	Peat

## Appendix C Assessing air permeability of older dwellings in relation to permanent ventilation requirements

- C.1 The minimum requirements for permanent ventilation for certain appliances depend on a knowledge of the air-tightness of the dwelling where they are to be installed, Dwellings built after 2008 are likely to have evidence of the air-tightness either through an individual air permeability test certificate or through representative testing of the same design of dwelling on the same housing development.
- C.2 Older houses are unlikely to have been tested and may not always achieve an air permeability of less than  $5.0 \text{ m}^3/(\text{h.m}^2)$  at 50 Pa unless the building fabric has been substantially upgraded. That would include all or most of the following measures:
- Full double (or triple) glazing
  - Effective closures on trickle vents and other controllable ventilation devices
  - All external doors with integral draught seals and letter box seals
  - Internal and external sealing around external doors and window frames
  - Filled cavity or solid walls
  - Impermeable overlay and edge sealing of suspended ground floors
  - Careful sealing at junctions between building elements such as between walls and floors or ceilings
  - Careful sealing around loft hatch
  - Careful sealing around chimney or flue penetrations
  - Careful sealing around internal soil pipe
  - Careful sealing around domestic water and heating pipes passing into externally ventilated spaces
  - Careful sealing of all service penetrations in the building fabric (electricity, gas, water, drainage, phone, TV aerial, etc.)
  - Internal warning pipe for WC
  - All cable channels for light switches and power sockets sealed
  - All cable entry for lighting and ceiling roses sealed. Recessed lighting should not penetrate ceilings separating loft spaces.
- C.3 Failure to implement even a few of these measures will typically mean that the overall air permeability will probably exceed  $5.0 \text{ m}^3/(\text{h.m}^2)$  at 50 Pa. However, individual rooms in some older houses with solid walls and solid floors can be inherently air-tight when fitted with modern glazing. The situation may therefore need to be assessed with respect both to the overall dwelling and to the individual room where the appliance is to be fitted. If in doubt then assume that the air permeability is lower than  $5.0 \text{ m}^3/(\text{h.m}^2)$  at 50 Pa and fit the appropriate permanent ventilation or seek specialist advice.

Further information on sources of air leakage can be found in GPG224  
Improving airtightness in dwellings published by the Energy Saving Trust.

## Appendix D Publications referred to

### **BS EN 303 Heating boilers.**

Part 1:1999 Heating boiler with forced draught burners. Terminology, general requirements, testing and marking.

### **BS EN 449:2002+A1:2007 Specification for Dedicated Liquefied Petroleum Gas Appliances. Domestic Flueless Space Heaters (Including Diffusive Catalytic Combustion Heaters).**

### **BS EN ISO 1182:2002 Reaction to fire tests for building products – Non-combustibility test.**

### **BS EN 1443:2003 Chimneys. General Requirements.**

### **BS EN 1457:1999 Chimneys. Clay/Ceramic Flue Liners. Requirements and Test Methods, AMD 14077.**

### **BS EN ISO 1716:2002 Reaction to fire tests for building products – Determination of heat of combustion.**

### **BS EN 1806:2006 Chimneys. Clay/Ceramic Flue Blocks for Single Wall Chimneys. Requirements and Test Methods.**

### **BS EN 1856 Chimneys. Requirements for metal chimneys.**

Part 1:2003 System chimney products.

Part 2:2004 Metal liners and connecting fluepipes.

### **BS EN 1857:2003 +A1:2008 Chimneys. Components-Concrete Flue Liners.**

### **BS EN 1858:2008 Chimneys. Components. Concrete flue blocks.**

### **BS EN 13141:2004 Ventilation for buildings. Performance testing of components/products for residential ventilation. Externally and internally mounted air transfer devices.**

### **BS EN 13384-1:2002+A1:2008 Chimneys. Thermal and fluid dynamic calculation methods. Chimneys serving one appliance.**

### **BS EN 13501 Fire classification of construction products and building elements.**

Part 1:2007 +A1:2008 Classification using test data from reaction to fire tests.

### **BS EN 13502:2002 Chimneys. Requirements and test methods for clay/ceramic flue terminals.**

### **BS EN 14213:2003 Heating fuels. Fatty acid methyl esters (FAME). Requirements and test methods.**

### **BS EN 14471:2005 Chimneys. System chimneys with plastic flue liners. Requirements and test methods.**

### **BS EN 15287 Chimneys. Design, installation and commissioning of chimneys. Chimneys for non-roomsealed heating appliances.**

**BS EN 50291:2001 Electrical apparatus for the detection of carbon monoxide in domestic premises. Test methods and performance requirements.**

**BS 41:1973 Specification for cast iron spigot and socket flue or smoke pipes and fittings.**

**BS 476:Fire Tests on Building Materials and Structures.**

Part 4:1970 Non-combustibility Test for Materials  
AMD 2483 and AMD 4390.

Part 11:1982 Method for Assessing the Heat Emission from Building Materials.

**BS 715:2005 Specification for metal flue boxes for gas-fired appliances not exceeding 20 kW.**

**BS 1251:1987 Specification for open fireplace components.**  
AMD 8454

**BS 2869:2006 Specification for fuel oils for agricultural and industrial engines and boilers.**

**BS 5410:Code of Practice for Oil Firing.**

Part 1:1997 Installations up to 45 kW Output Capacity for Space Heating and Hot Water Supply Purposes,  
AMD 11022 and Corrigendum AMD 13155.

Part 2:1978 Installations of 45 kW or Above Output Capacity for Space Heating, Hot Water and Steam Supply Purposes,  
AMD 3638 and AMD 13229.

**BS 5440:Fluing and ventilation for gas appliances of rated input not exceeding 70 kW net (1st, 2nd and 3rd Family Gases).**

Part 1:2008 Specification for Installation and maintenance of Flues,  
AMD 13983

Part 2:2009 Specification for Installation and Maintenance of Ventilation for Gas Appliances,  
AMD 13368

**BS 5871: Specification for Installation and maintenance of Gas Fires, Convector Heaters, Fire/Back Boilers and Decorative Fuel Effect Gas Appliances.**

Part 3:2005 Decorative Fuel Effect Gas Appliances of Heat Input Not Exceeding 20 kW (2nd and 3rd Family Gases)

**BS 6999:1989 Specification for Vitreous-Enamelled Low-Carbon-Steel Fluepipes, Other Components and Accessories for Solid-Fuel-Burning Appliances with a Maximum Rated Output of 45kW**  
**AMD 8949**

**BS 8303 Installation of domestic heating and cooking appliances burning solid mineral fuels**

Part 1:1994 Design of installations

Part 2:1994 Specification for Installing and Commissioning on Site

## **Chartered Institution of Building Services Engineers**

CIBSE Guide B: Heating, Ventilating, Air Conditioning and Refrigeration, (2005).

## **Energy Saving Trust**

GPG224 Improving airtightness in dwellings (2005)

## **Oil Firing Technical Association (OFTEC)**

### **OFTEC Oil-fired appliance standards.**

OFS A100:2004 Heating boilers with atomising burners. Outputs up to 70kW. Maximum operating pressure of 3 Bar.

OFS A101:2004 Oil fired cookers with atomising or vaporising burners, with or without boilers. Heat outputs up to 45kW.

OFS A102:2004 Roomheaters with atomising or vaporising burners, with or without boilers, heat outputs up to 25kW.

OFS T100:2008 Oil firing equipment standard. Polyethylene oil storage tanks and tank bunds for distillate fuels.

### **OFTEC Technical Booklets**

Technical Booklet 2 Service and commissioning oil fired systems (pressure jet appliances).

Technical Booklet 4 Oil fires appliance and system installation requirements.

Technical Booklet 5 Service and commissioning oil fired systems (vaporising appliances)

## **LPG Gas Association**

### **Code of practice 1 Bulk LPG storage at fixed installations.**

Part 1 Design, installation and operation of vessels located above ground. (2009)

Part 2 Small bulk installations for domestic purposes (2000)

Part 3 Examination and inspection (2006)

Part 4 Buried/ Mounded LPG storage vessels (2008)

### **Code of Practice 24: Use of LPG Cylinders**

Part 1: The use of propane cylinders at residential premises and similar premises